

OWNER'S MANUAL

19-INCH COLOR TV/VCR

TVCR19D1

Symphonic

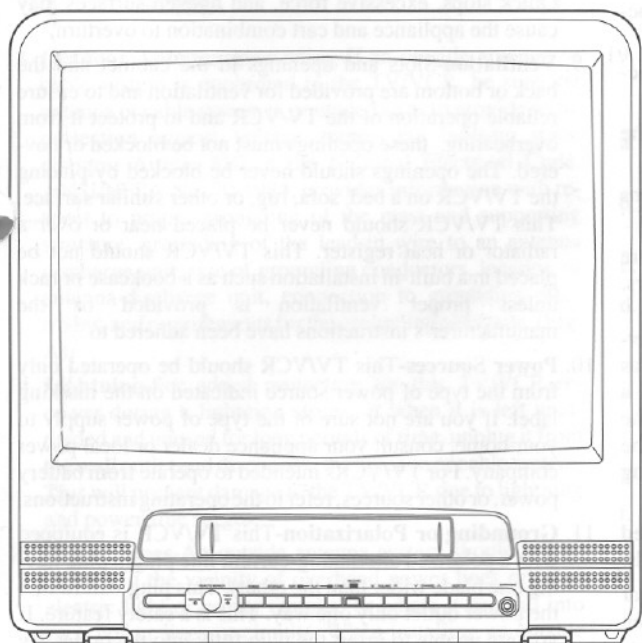

TABLE OF CONTENTS

IMPORTANT SAFEGUARDS	2
PRECAUTIONS.....	4
SUPPLIED ACCESSORIES.....	4
FEATURES.....	5
OPERATING CONTROLS AND FUNCTIONS.....	6
REMOTE CONTROL OPERATION	8
HOW TO USE REMOTE CONTROL	8
INSTALLING THE BATTERIES.....	9
ANTENNA CONNECTIONS	10
VHF/UHF COMBINED ANTENNA	10
VHF/UHF SEPARATE ANTENNAS.....	10
CABLE WITHOUT	
CONVERTER/DESCRAMBLER BOX.....	11
CABLE WITH	
CONVERTER/DESCRAMBLER BOX.....	11
EXTERNAL INPUT MODE	12
TV/CATV CHANNEL MEMORY	
PROGRAMMING.....	13
TO PRESET CHANNEL MEMORY AGAIN.....	14
TO DELETE OR ADD PRESET CHANNEL.....	15
SETTING THE CLOCK	16
TO CHANGE THE LANGUAGE.....	17
TV OPERATION	18
VIEWING AND RECORDING THE SAME	
PROGRAM	19
AUTOMATIC TIMER RECORDING	20
TODAY TIMER RECORDING	23
OTR (ONE TOUCH RECORDING).....	26
COUNTER MEMORY	27
TIME SEARCH.....	28
CHECKING THE COUNT, CLOCK AND	
CHANNEL NUMBER.....	29
SETTING THE SLEEP TIMER	29
PLAYBACK.....	30
RENTAL PLAY.....	30
AUTO REPEAT PLAYBACK	31
GAME MODE.....	31
CLOSED CAPTION SYSTEM	32
SPECIAL FEATURES.....	33
VIDEO CASSETTE.....	35
TROUBLESHOOTING GUIDE.....	36
MAINTENANCE.....	37
CABINET CLEANING	37
HEAD CLEANING	37
SERVICING.....	37
SPECIFICATIONS	38
GENERAL SPECIFICATIONS.....	38
ELECTRICAL SPECIFICATIONS.....	38
OTHER SPECIFICATIONS	38
CABLE CHANNEL DESIGNATIONS	39

IF YOU NEED ADDITIONAL ASSISTANCE FOR SET-
UP OR OPERATING AFTER READING OWNER'S
MANUAL, PLEASE CALL TOLL FREE
1-800-242-7158 (EASTERN TIME 9:00AM ~ 4:30PM)

VHS

Please read before using this equipment

WARNING:

TO REDUCE THE RISK OF FIRE OR ELECTRIC SHOCK, DO NOT EXPOSE THIS APPLIANCE TO RAIN OR MOISTURE.



CAUTION

**RISK OF ELECTRIC SHOCK
DO NOT OPEN**



CAUTION: TO REDUCE THE RISK OF ELECTRIC SHOCK, DO NOT REMOVE COVER (OR BACK) NO USER SERVICEABLE PARTS INSIDE. REFER SERVICING TO QUALIFIED SERVICE PERSONNEL.



THIS SYMBOL INDICATES THAT DANGEROUS VOLTAGE CONSTITUTING A RISK OF ELECTRIC SHOCK IS PRESENT WITHIN THIS UNIT.



THIS SYMBOL INDICATES THAT THERE ARE IMPORTANT OPERATING AND MAINTENANCE INSTRUCTIONS IN THE LITERATURE ACCOMPANYING THE APPLIANCE.

The important note is located on the rear of the cabinet.

IMPORTANT SAFEGUARDS

- 1. Read instructions**-All the safety and operating instructions should be read before the appliance is operated.
- 2. Retain Instructions**-The safety and operating instructions should be retained for future reference.
- 3. Heed Warnings**-All warnings on the appliance and in the operating instructions should be adhered to.
- 4. Follow Instructions**-All operating and use instructions should be followed.
- 5. Cleaning**-Unplug TV/VCR from the wall outlet before cleaning. Do not use liquid cleaners or aerosol cleaners. Use a damp cloth for cleaning.
EXCEPTION: A product that is meant for uninterrupted service and that for some specific reason, such as the possibility of the loss of an authorization code for a CATV converter, is not intended to be unplugged by the user for cleaning or any other purpose, may exclude the reference to unplugging the appliance in the cleaning description otherwise required in item 5.
- 6. Attachments**-Do not use attachments not recommended by the TV/VCR manufacturer as they may cause hazards.
- 7. Water and Moisture**-Do not use this TV/VCR near water-for example, near a bath tub, wash bowl, kitchen sink, or laundry tub, in a wet basement, or near a swimming pool, and the like.
- 8. Accessories**-Do not place this TV/VCR on an unstable cart, stand, tripod, bracket, or table. The TV/VCR may fall, causing serious injury to someone, and serious damage to the appliance. Use only with a cart, stand, tripod, bracket, or table recommended by the manufacturer, or sold with the TV/VCR. Any mounting of the appliance should follow the manufacturer's instructions and should use a mounting accessory recommended by the manufacturer. An appliance and cart combination should be moved with care.
- 9. Ventilation**-Slots and openings in the cabinet and the back or bottom are provided for ventilation and to ensure reliable operation of the TV/VCR and to protect it from overheating, these openings must not be blocked or covered. The openings should never be blocked by placing the TV/VCR on a bed, sofa, rug, or other similar surface. This TV/VCR should never be placed near or over a radiator or heat register. This TV/VCR should not be placed in a built-in installation such as a bookcase or rack unless proper ventilation is provided or the manufacturer's instructions have been adhered to.
- 10. Power Sources**-This TV/VCR should be operated only from the type of power source indicated on the marking label. If you are not sure of the type of power supply to your home, consult your appliance dealer or local power company. For TV/VCRs intended to operate from battery power, or other sources, refer to the operating instructions.
- 11. Grounding or Polarization**-This TV/VCR is equipped with a polarized alternating-current line plug (a plug having one blade wider than the other). This plug will fit into the power outlet only one way. This is a safety feature. If you are unable to insert the plug fully into the outlet, try reversing the plug. If the plug should still fail to fit, contact your electrician to replace your obsolete outlet. Do not defeat the safety purpose of the polarized plug.
- 12. Power-Cord Protection**-Power-supply cords should be routed so that they are not likely to be walked on or pinched by items placed upon or against them, paying particular attention to cords at plugs, convenience receptacles, and the point where they exit from the appliance.

PORTABLE CART WARNING



S3126A

FIGURE A
EXAMPLE OF ANTENNA GROUNDING AS PER
NATIONAL ELECTRICAL CODE

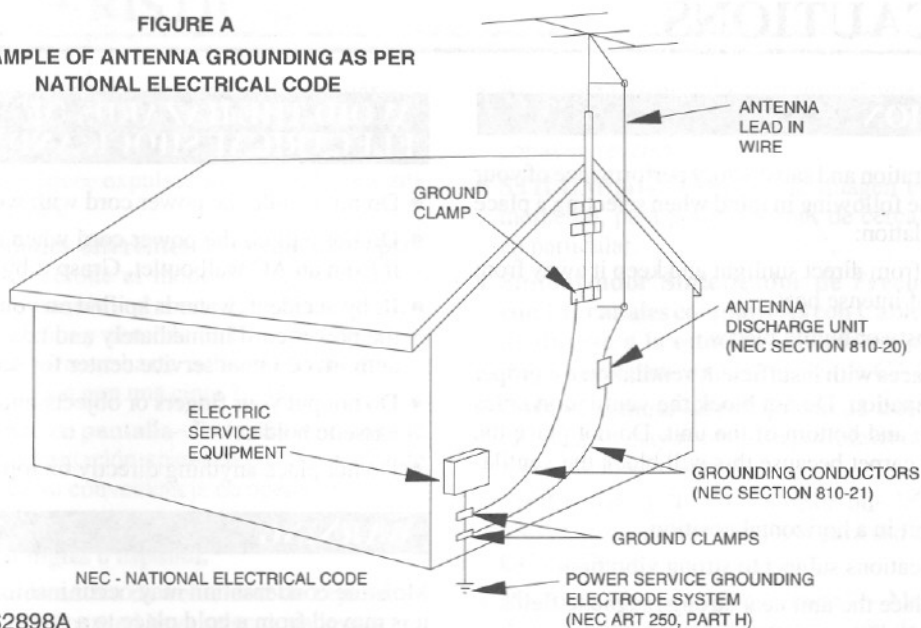

S2898A

13. **Outdoor Antenna grounding-**If an outside antenna or cable system is connected to the TV/VCR, be sure the antenna or cable system is grounded so as to provide some protection against voltage surges and built-up static charges. Article 810 of the National Electrical Code, ANSI/NFPA No. 70-1984, provides information with respect to proper grounding of the mast and supporting structure, grounding of the lead-in wire to an antenna discharge unit, size of grounding conductors, location of antenna-discharge unit, connection to grounding electrodes, and requirements for the grounding electrode. (Fig. A)
14. **Lightning-**For added protection for this TV/VCR receiver during a lightning storm, or when it is left unattended and unused for long periods of time, unplug it from the wall outlet and disconnect the antenna or cable system. This will prevent damage to the TV/VCR due to lightning and power-line surges.
15. **Power Lines-**An outside antenna system should not be located in the vicinity of overhead power lines or other electric light or power circuits, or where it can fall into such power lines or circuits. When installing an outside antenna system, extreme care should be taken to keep from touching such power lines or circuits as contact with them might be fatal.
16. **Overloading-**Do not overload wall outlets and extension cords as this can result in a risk of fire or electric shock.
17. **Object and Liquid Entry-**Never push objects of any kind into this TV/VCR through openings as they may touch dangerous voltage points or short out parts that could result in a fire or electric shock. Never spill liquid of any kind on the TV/VCR.
18. **Servicing-**Do not attempt to service this TV/VCR yourself as opening or removing covers may expose you to dangerous voltage or other hazards. Refer all servicing to qualified service personnel.
19. **Damage Requiring Service-**Unplug this TV/VCR from the wall outlet and refer servicing to qualified service personnel under the following conditions:
 - a. When the power-supply cord or plug is damaged or frayed.
 - b. If liquid has been spilled, or objects have fallen into the TV/VCR.
 - c. If the TV/VCR has been exposed to rain or water.
 - d. If the TV/VCR does not operate normally by following the operating instructions. Adjust only those controls that are covered by the operating instructions, as improper adjustment of other controls may result in damage and will often require extensive work by a qualified technician to restore the TV/VCR to its normal operation.
 - e. If the TV/VCR has been dropped or damaged in any way.
 - f. When the TV/VCR exhibits a distinct change in performance-this indicates a need for service.
20. **Replacement Parts-**When replacement parts are required, be sure the service technician has used replacement parts specified by the manufacturer that have the same characteristics as the original part. Unauthorized substitutions may result in fire, electric shock, injury to persons or other hazards.
21. **Safety Check-**Upon completion of any service or repairs to this TV/VCR, ask the service technician to perform routine safety checks to determine that the TV/VCR is in proper operating condition.
22. **Heat-**This TV/VCR products should be situated away from heat sources such as radiators, heat registers, stoves, or other products (including amplifiers) that produce heat.

PRECAUTIONS

LOCATION

For safe operation and satisfactory performance of your unit, keep the following in mind when selecting a place for its installation:

- Shield it from direct sunlight and keep it away from sources of intense heat.
- Avoid dusty or humid places.
- Avoid places with insufficient ventilation for proper heat dissipation. Do not block the ventilation holes at the top and bottom of the unit. Do not place the unit on a carpet because this will block the ventilation holes.
- Install unit in a horizontal position.
- Avoid locations subject to strong vibration.
- Do not place the unit near strong magnetic fields.
- Do not move the unit from a cold to a hot place or vice versa.

AVOID THE HAZARDS OF ELECTRICAL SHOCK AND FIRE

- Do not handle the power cord with wet hands.
- Do not pull on the power cord when disconnecting it from an AC wall outlet. Grasp it by the plug.
- If, by accident, water is spilled on your unit, unplug the power cord immediately and take the unit to an authorized Funai service center for servicing.
- Do not put your fingers or objects into the TV/VCR cassette holder.
- Do not place anything directly on top of the unit.

WARNING

Moisture condensation may occur inside the unit when it is moved from a cold place to a warm place, or after heating a cold room or under conditions of high humidity. If a tape is played in a TV/VCR which has moisture, it may damage the tape and TV/VCR. Therefore when the condensation occurs inside the unit turn the POWER button on and allow at least 2 hours for the unit to dry out.

IMPORTANT COPYRIGHT INFORMATION

Unauthorized recording or use of broadcast television programming, video tape, film or other copyrighted material may violate applicable copyright laws. We assume no responsibility for the unauthorized duplication, use or other acts which infringe upon the rights of copyright owners.

SUPPLIED ACCESSORIES

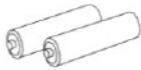
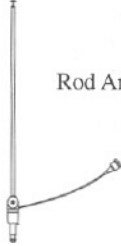
<p>Remote Control Unit</p>  <p>PART NO. (UREMT32MM006)</p>	<p>2 AA Batteries</p> 	<p>Rod Antenna</p>  <p>(OEMN00454)</p>
---	---	---

- If you need to replace these accessories, please refer to the PART NO. under the illustrations and contact the FUNAI parts department for ordering.

FEATURES

- **Auto Power On and Off system**— Automatically turns the TV/VCR on as you insert the cassette, and turns off after auto-rewind, ejects when the beginning of the tape is reached.
- **Three Different Record/Playback Speed**— Select SP mode (Standard play), LP mode (Long play) and SLP mode (Super long play) for up to eight hours of recording/playback with a T-160 tape.
- **On Screen Programming**— All major operating and programming functions appear on your TV/VCR screen for operating convenience.
- **Bilingual on screen menu display selectable in English or Spanish**
- **Automatic Playback Speed Selection**— Automatically selects the proper playback speed even if you select a different speed.
- **1 Year, 8 Events Timer (including Today, Daily and Weekly Timer Recording)**— The built-in timer allows you to record up to 7 programs at different times on different channels up to 1 year in advance. The Today Timer Recording feature uses program number 8. The daily timer will allow recordings to be made of daily broadcasts and the weekly timer will allow recording to be made once a week up to the end of the tape.
- **Today Timer Recording**— Allows you to easily record one program within 24 hours.
- **Visual Search**— Allows you to view a video tape at a high speed in either a forward or reverse direction.
- **STILL**— "Freeze" the picture at any time, for close viewing of a particular scene.
- **181 Channel Cable-compatible PLL Frequency Synthesizer Tuner with Direct station Call**— (A CATV Box may be necessary to view scrambled CATV channels.)
- **Infrared Remote control unit**— Allows you to use most of the controls from a remote location.
- **GAME MODE**— Makes the picture suitable for use with a TV GAME.
- **Rental Play Mode**— Improves playback picture quality of worn tapes, especially rental tapes.
- **Auto Repeat Playback**— Allows you to repeat a tape indefinitely without using the PLAY button.
- **OTR (One Touch Recording)**— Automatic timed recording from 30 to 480 minutes is possible at the push of OTR button. (Timer adjustments for recording are not required.)
- **CCS (Closed Caption System)**— You may view specially labeled (cc) TV programs, movies, news, prerecorded tapes, etc. with either a dialogue caption or text display added to the program.
- **Time Search**— Allows you to set the TV/VCR to advance the tape by entering the desired playback time you want to skip.

The serial number of this product may be found on the back of the unit. No others have the same serial number as yours. You should record the number and other vital information here and retain this book as a permanent record of your purchase to aid identification in case of theft.

Date of Purchase	
Dealer Purchase from	
Dealer Address	
Dealer Phone No.	
Model No.	TVCR19D1
Serial No.	

OPERATING CONTROLS AND FUNCTIONS

— FRONT VIEW —

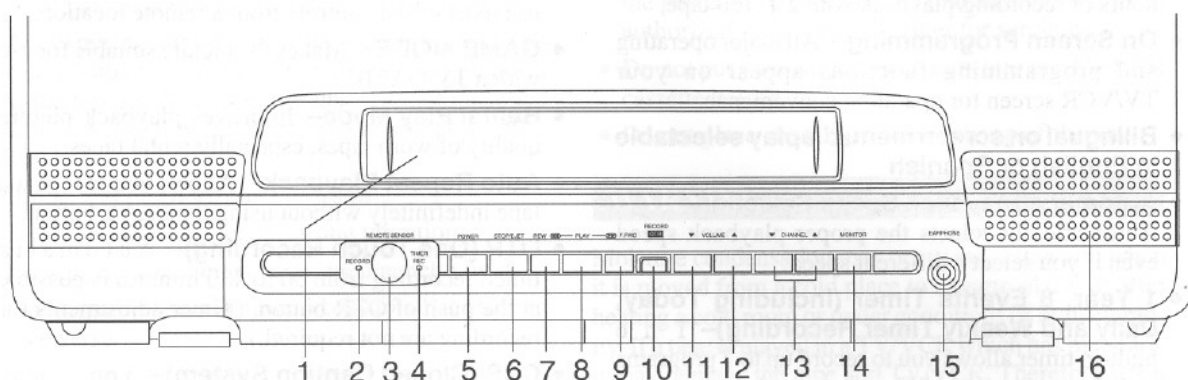

Note: This unit does not have a stereo speaker system.

- 1 CASSETTE COMPARTMENT**
- 2 RECORD indicator**— Lights when in the Recording mode.
- 3 Remote Sensor**— Receives the infrared control signals from the handheld remote control unit.
- 4 TIMER REC. indicator**— Lights when in the Timer Recording mode.
- 5 POWER button**— Press to turn TV/VCR on and off. Press to activate the automatic timer recording.
- 6 STOP/EJECT button**— Press to stop tape motion. Press to remove tape from TV/VCR.
- 7 REW button**— Press to rewind tape, or to view video in reverse during the Play mode at a faster than normal speed. Press PLAY button to return TV/VCR to normal playback speed.
- 8 PLAY button**— Press to begin playback of a tape.
- 9 F.FWD button**— Press to advance tape, or to view video in forward during Play mode at a faster than normal speed. Press PLAY button to return TV/VCR to normal playback speed.
- 10 RECORD/OTR button**— Press to begin manual recording. Press to activate One Touch Recording.
- 11 VOLUME "v" button**— Press to adjust the volume level.
CLEAR function— Press to cancel Today Timer Recording.
- 12 VOLUME "^" button**— Press to adjust the volume level.
SELECT function— Press to select next step when setting Today Timer Recording.
- 13 CHANNEL "v"/"v" buttons**— Press to select the channel for viewing or recording.
TRACKING +/- function— Press to minimize video 'noise' (lines or dots on screen) during the Play mode.
SET function— Press to adjust time using "^" or "v" button in the Today Timer Recording.
- 14 MONITOR button**— Press to turn the TV/VCR screen on and off when in the Recording mode.
TODAY TIMER RECORDING function— Press to set Today Timer Recording.
- 15 EARPHONE jack**— For connection to earphone (not supplied) for personal listening.
- 16 SPEAKER**

— REAR VIEW —

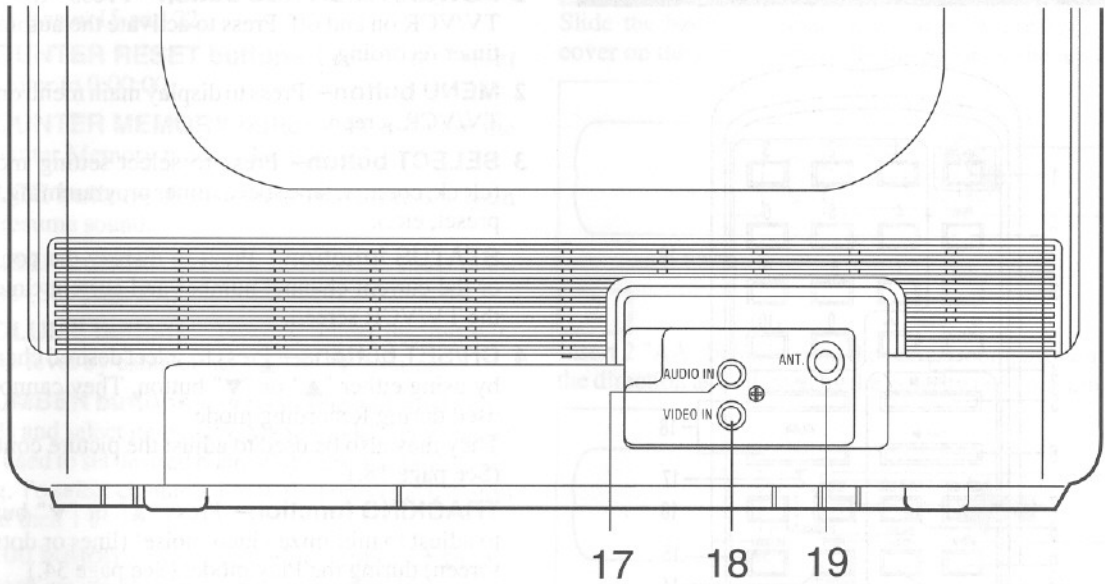

- 17 AUDIO IN jack**— For connection to audio output jack of your audio equipment or another VCR.
- 18 VIDEO IN jack**— For connection to video output jack of your video camera or another VCR.
- 19 ANT. terminal**— For connection to an antenna or CATV.

REMOTE CONTROL OPERATION

You can operate most of functions from the Remote Control (included). The buttons on the Remote Control have the same functions as the corresponding buttons on the unit.

HOW TO USE REMOTE CONTROL

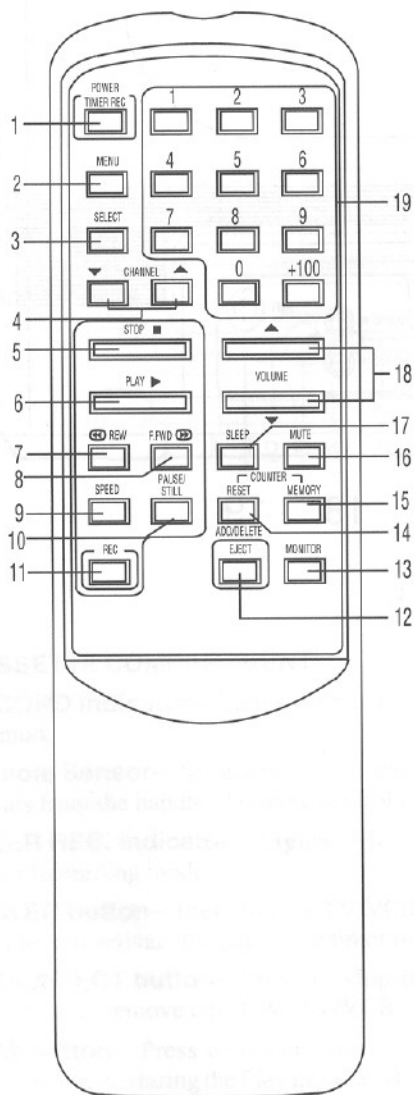

1 POWER/TIMER REC button— Press to turn TV/VCR on and off. Press to activate the automatic timer recording.

2 MENU button— Press to display main menu on the TV/VCR screen.

3 SELECT button— Press to select setting modes (clock, counter, tape speed, timer programming, CH preset, etc.).

STATUS function— Press to display the counter or the current channel number and current time on the TV/VCR screen.

4 CH/SET buttons— Press to select desired channel by using either "▲" or "▼" button. They cannot be used during Recording mode.

They may also be used to adjust the picture control. (See page 18.)

TRACKING function— Press "▲" or "▼" button to adjust to minimize video 'noise' (lines or dots on screen) during the Play mode. (See page 34.)

5 STOP button— Press to stop the tape motion.

6 PLAY button— Press to playback the tape.

7 REW button— Press to rewind the tape, or to view the picture rapidly in reverse during the Play mode. (Rewind Search)

8 F.FWD button— Press to rapidly advance the tape, or to view the picture rapidly in forward during the Play mode. (Forward Search)

9 SPEED button— Press to set desired recording speed. (SP/LP/SLP)

10 PAUSE/STILL button— Press to temporarily stop the tape during the Recording mode or to view a still picture during the Play mode.

11 REC button— Press to begin manual recording.

12 EJECT button— Press to remove tape from the TV/VCR.

13 MONITOR button— Press to turn the TV/VCR screen on and off when in the Recording mode.

14 ADD/DELETE button— Press to add or delete channel numbers. Press to cancel a timer program. (This function is operative only in the Menu mode.) (See pages 15 and 22.)

COUNTER RESET button— Press to reset counter to 0:00:00.

15 COUNTER MEMORY button— Press to use the Counter Memory mode. (See page 27.)

16 MUTE button— Press to mute sound. Press it again to resume sound.

17 SLEEP button— Press to activate the sleep function. (See page 29.)

18 VOLUME buttons— Press to adjust desired volume level by using either "▲" or "▼" button.

19 NUMBER buttons— Press to select desired channels and select item in the Menu mode. They cannot be used to set desired channel during Timer Recording. To select channels 1 to 9, first press the 0 button and then 1 to 9.

+100 button— Press to select cable channels which are equal or greater than number 100.

INSTALLING THE BATTERIES

1

Slide the battery compartment cover by pressing the cover on the remote unit in the direction of the arrow.

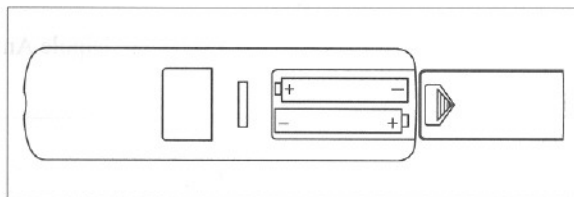

2

Insert 2 "AA" batteries into the battery compartment in the direction as indicated by the polarity (+/-) markings.

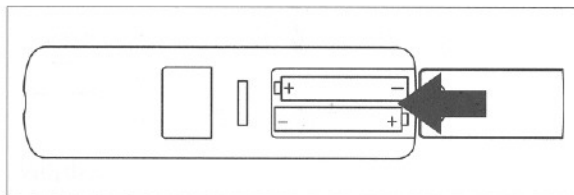

3

Replace the cover.

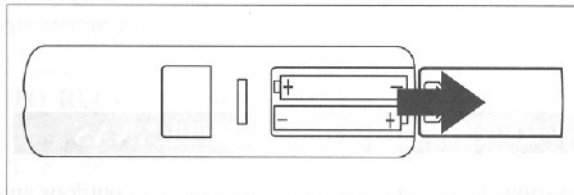

ANTENNA CONNECTIONS

VHF/UHF COMBINED ANTENNA

The VHF/UHF Rod Antenna (supplied) is detachable. Push the stem of the antenna into the hole which is located on the upper back cabinet of the unit.

Connect the VHF/UHF Rod Antenna or VHF/UHF Combination Antenna to the ANT. terminal of the TV/VCR as shown in the diagram below.

For the best reception, extend the VHF/UHF Dipole Antenna fully and adjust its position. (Avoid handling the top section when making adjustments.)

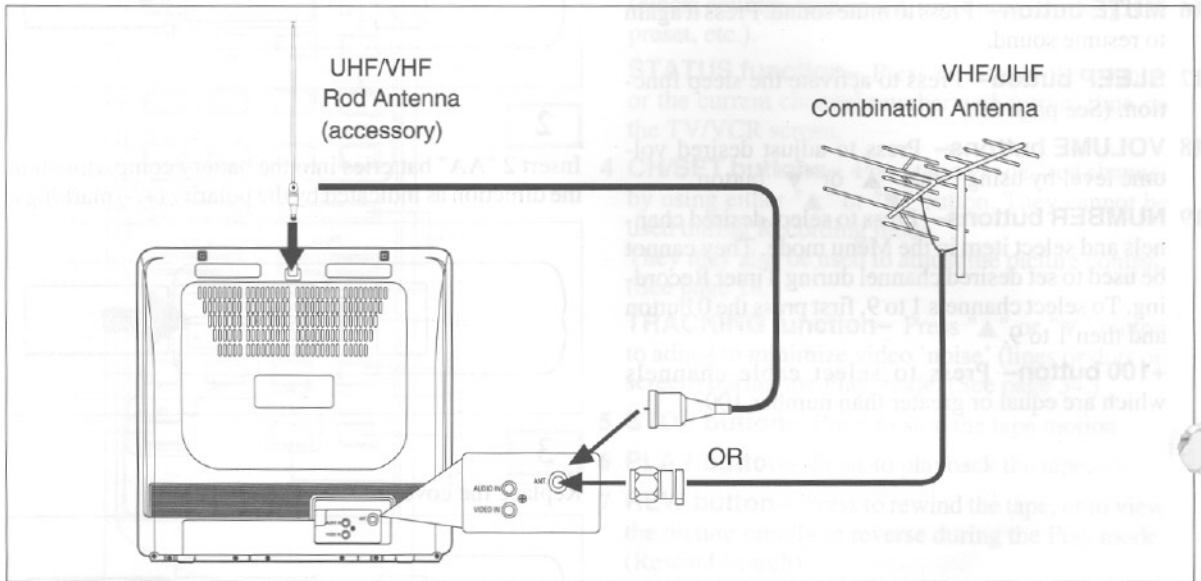

VHF/UHF SEPARATE ANTENNAS

In some areas it will be necessary to use an outdoor antenna.

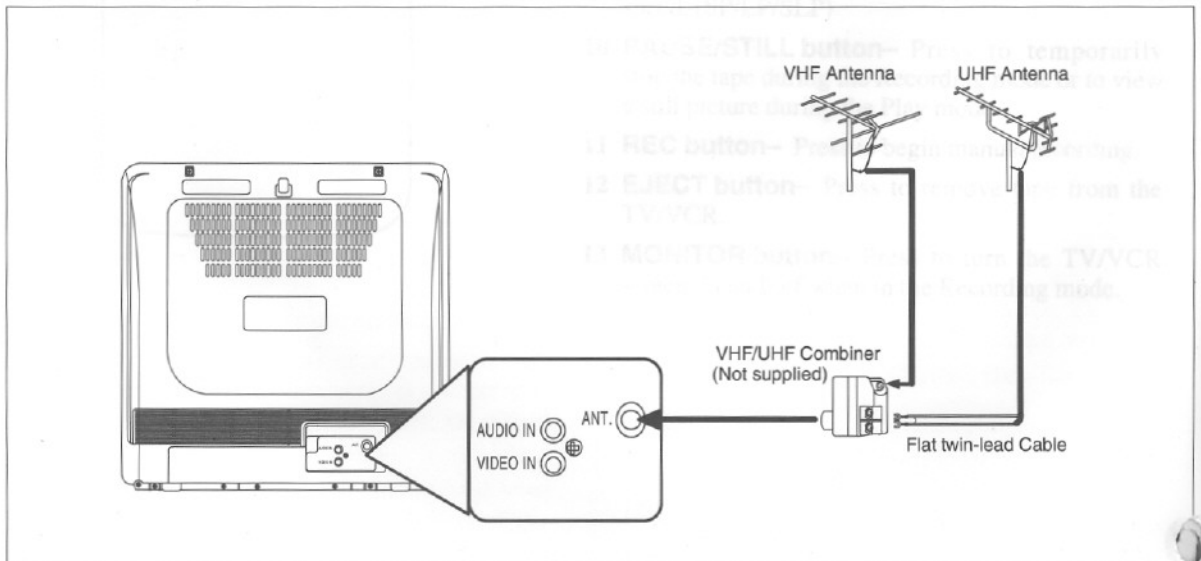

CABLE WITHOUT CONVERTER/DESCRAMBLER BOX

Use this connection if your cable system connects directly to your TV/VCR without a converter box.

With this connection you, 1) can use your TV/VCR Remote Control to select channels, 2) program one or more unscrambled channels for unattended recording.

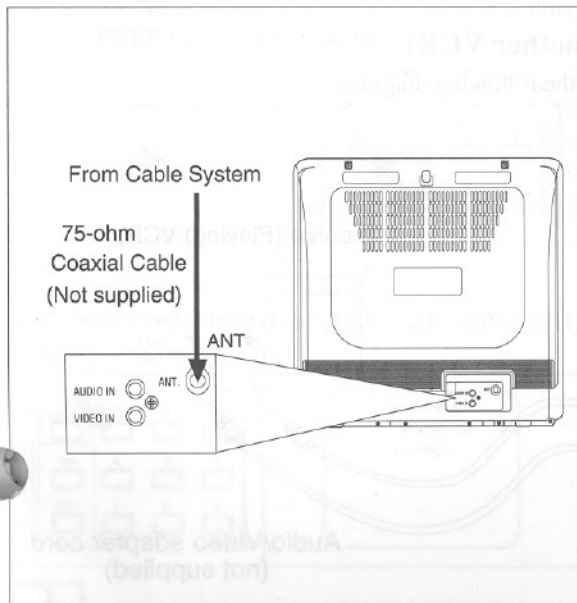

CABLE WITH CONVERTER/DESCRAMBLER BOX

If your cable service supplies you with a converter box you can use the basic connection shown here.

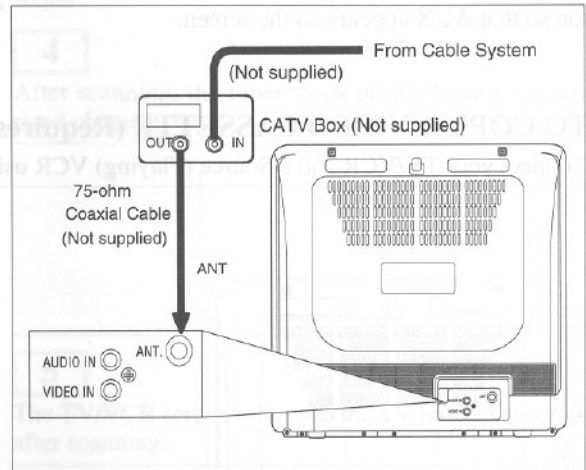

With this connection you can record and view any channel, including scrambled channels. However, channel selection must be made at the cable company converter box. This means that channels cannot be changed using the TV/VCR Remote Control. Unattended recording is limited to one channel at a time.

TO RECORD AND VIEW A SCRAMBLED/UNSCRAMBLED CHANNEL

1. Set the TV/VCR channel selector to the output channel of the Cable Converter Box. (Ex. CH3)
2. Select the channel to be recorded or viewed on the Cable Converter Box.

Note to CATV system installer

This reminder is provided to call the CATV system installer's attention to Article 820-40 of the NEC that provides guidelines for proper grounding and, in particular, specifies that the cable ground shall be connected to the grounding system of the building as close to the point of cable entry as practical.

EXTERNAL INPUT MODE

When using an external input signal, connect the player's audio/video output cables to the AUDIO IN, VIDEO IN jacks of your TV/VCR. Then press CHANNEL "▲" or "▼" button or enter "00" with number button so that AUX appears on the screen.

AUX

TO COPY A VIDEO CASSETTE (Requires another VCR)

Connect your TV/VCR and a Source (Playing) VCR using the following diagram:

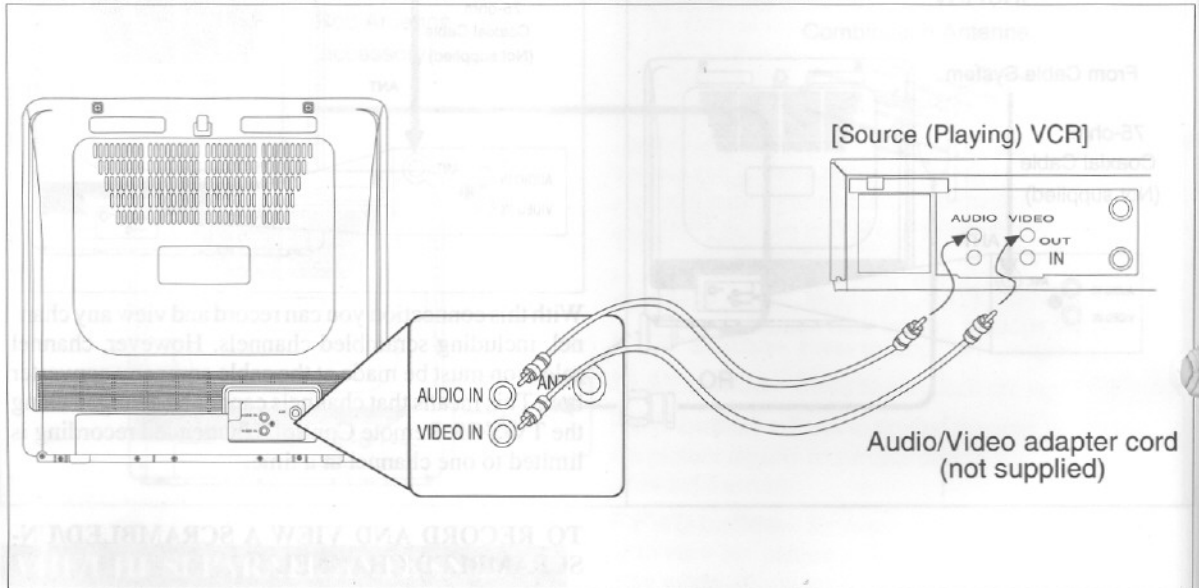

1. Insert a pre-recorded video cassette into the Source (Playing) VCR.
2. Insert a blank video cassette, or one you want to record over, into the TV/VCR's cassette compartment.
3. Press SPEED button on the TV/VCR to select the desired recording speed (**SP**, **LP** or **SLP**).
4. Press CH. ▲ or ▼ button repeatedly so that "AUX" appears on the screen.
5. Begin playback of the tape in the Source (Playing) VCR.
6. Press RECORD button on the TV/VCR.

NOTE: For best results during dubbing, use the TV/VCR's front panel controls whenever possible. The remote control might affect the TV/VCR's playback operation.

TV/VCR CHANNEL MEMORY PROGRAMMING

You can program the tuner to scan only the channels you receive in your area.

AUTOMATIC CHANNEL MEMORY

NOTE: Channel memory programming is not needed when using a converter/descrambler box.

You must use the remote control unit for the following steps:

1

Plug the TV/VCR power cord into a standard AC outlet. Press POWER button to turn on the TV/VCR.

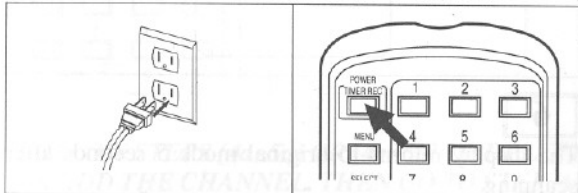

2

Select item 1 (ENGLISH) or 2 (ESPAÑOL=SPANISH) using number button.

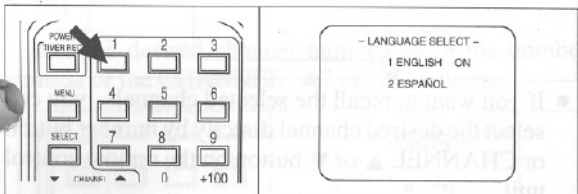

3

Press SELECT button on the remote control unit. The tuner scans and memorizes all the active channels in your area.

The TV/VCR distinguishes between standard TV channels and CATV.

(TV mode: from CH 02/ CATV mode: from CH 01)

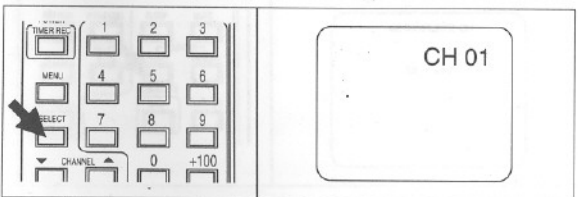

4

After scanning, the tuner stops on the lowest memorized channel.

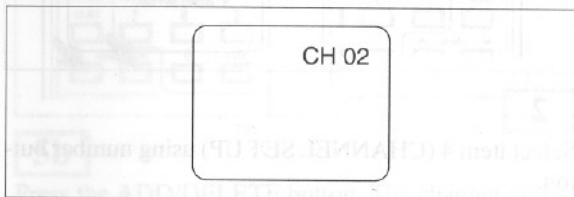

5

The TV/VCR screen returns to the TV mode 5 seconds after scanning.



- If you want to recall the selected channels, you can select the desired channel directly by number button or CHANNEL ▲ or ▼ button on the remote control unit.

TO RETURN TO TV MODE IN TUNER SET UP MODE

Press MENU button in Tuner Set Up mode.



TO PRESET CHANNEL MEMORY AGAIN

1

Press MENU button.

The main menu display appears on the TV/VCR screen.

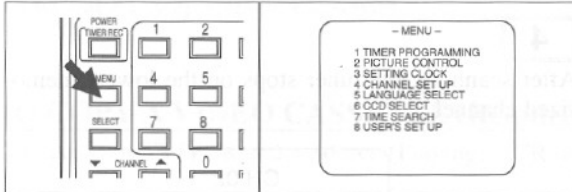

2

Select item 4 (CHANNEL SET UP) using number button.

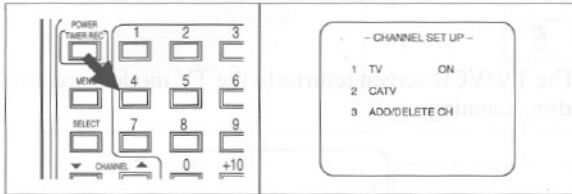

3

Select item 1 (TV) or 2 (CATV) using number button. (Example: TV)

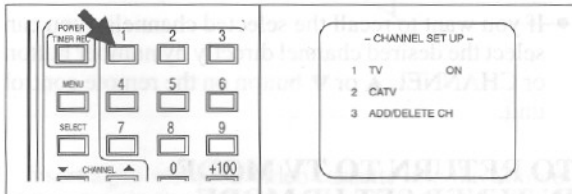

4

Press SELECT button. The tuner scans and memorizes all the active channels in your area.

(TV mode: from CH02 / CATV mode: from CH01)

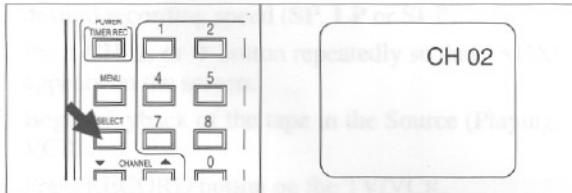

5

After scanning, the tuner stops on the lowest memorized channel.

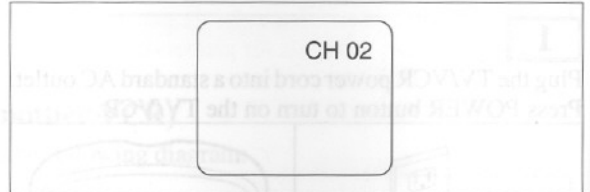

6

The display returns to original mode 5 seconds after scanning.



- If you want to recall the selected channels, you can select the desired channel directly by number button or CHANNEL ▲ or ▼ button on the remote control unit.

TO RETURNS TO TV MODE IN TUNER SET UP MODE

Press MENU button in Tuner Set Up mode.



TO DELETE OR ADD PRESET CHANNEL

To add or delete the desired channels. Follow steps [1] and [2] on page 14, then step [3] below.

3

Select item 3 (ADD/DELETE CH) using number button.

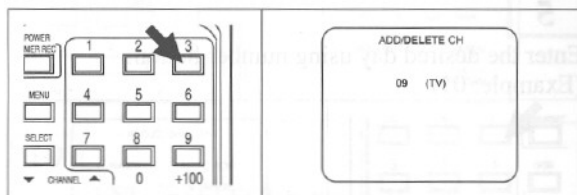

FOLLOW STEPS [4a~5a] OR [4b~5b] TO DELETE OR ADD THE CHANNEL. THEN GO TO STEP [6].

DELETING PRESET CHANNEL

4a

Enter the desired channel number using the number button or the CHANNEL "▲" or "▼" button.

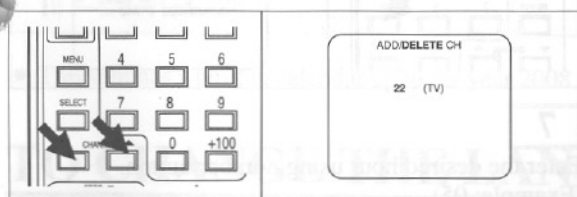

5a

Press ADD/DELETE button. The channel number changes to light red. The channel is deleted from memory.

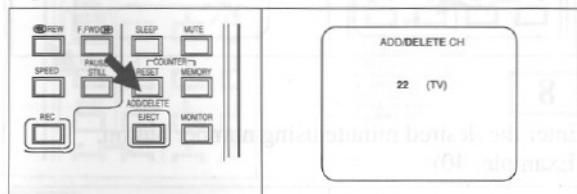

Notes:

- To delete another channel, repeat steps [4a] and [5a].
- If you press the ADD/DELETE button again, the channel is memorized again.

ADDING PRESET CHANNEL

4b

Select the desired channel number using the number buttons or the CHANNEL "▲" or "▼" button.

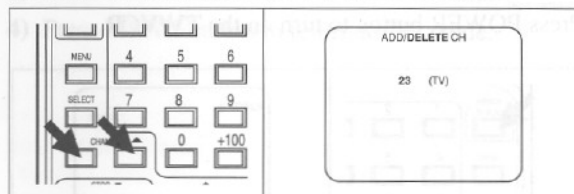

5b

Press the ADD/DELETE button. The channel number changes to light blue. The channel is added to memory.

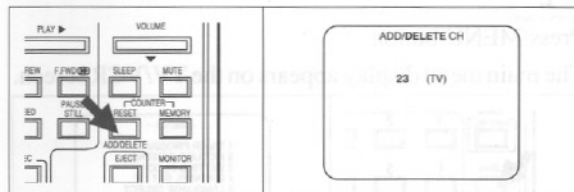

Notes:

- To add another channel, repeat steps [4b] and [5b].
- If you press the ADD/DELETE button again, the channel is deleted again.

NOTE:

**Added channel is in light blue.
Deleted channel is in light red.**

6

Press MENU button. The TV/VCR screen returns to TV mode.

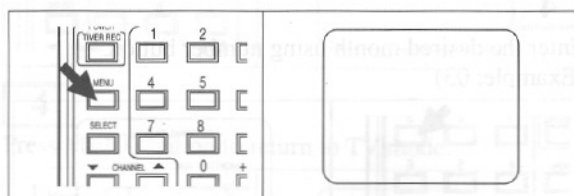

Note: To confirm that channel(s) has been deleted or added, press CHANNEL "▲" or "▼" button.

SETTING THE CLOCK

Set the clock accurately for proper automatic timer recording.

In the example below, the clock is to be set to:

DATE March 1st, 1994

SETTING TIME 5:40PM

You must use the remote control unit for the following steps:

1

Press POWER button to turn on the TV/VCR.

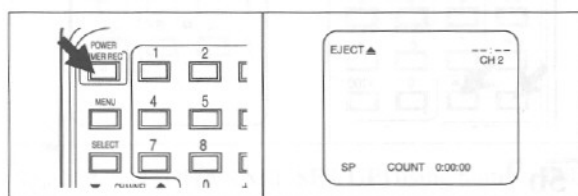

2

Press MENU button.

The main menu display appears on the TV/VCR screen.

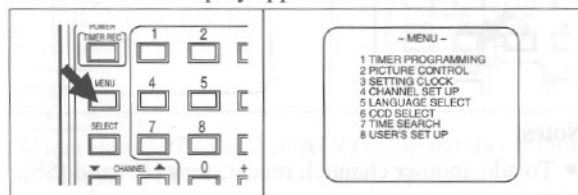

3

Select item 3 (SETTING CLOCK) using number button. "SETTING CLOCK" appears on the TV/VCR screen. The MONTH digits flash.

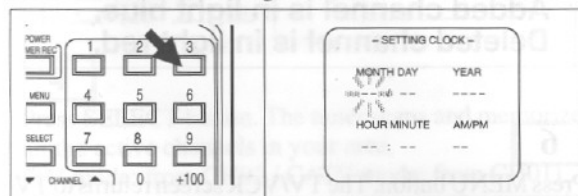

4

Enter the desired month using number button. (Example: 03)

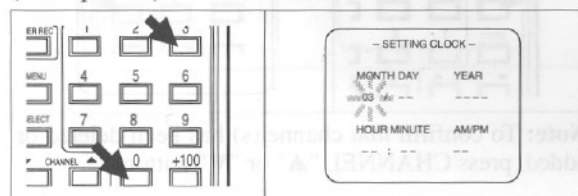

5

Enter the desired day using number button. (Example: 01)

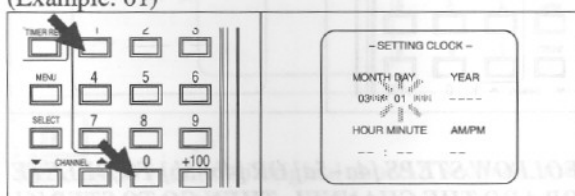

6

Enter the desired year using number button. (Example: 1994)

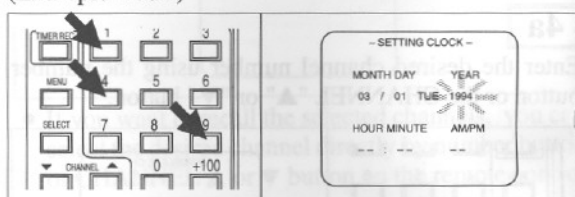

7

Enter the desired hour using number button. (Example: 05)

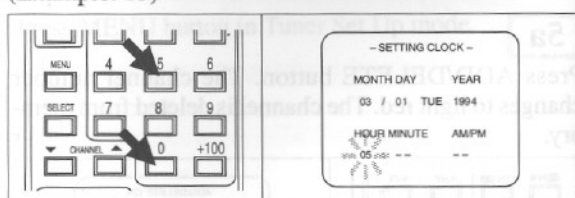

8

Enter the desired minute using number button. (Example: 40)

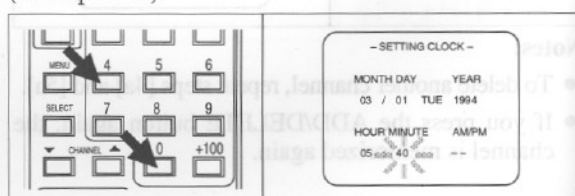

9

Enter 1 to select AM or enter 2 to select PM using number button. (Example: 2→PM)

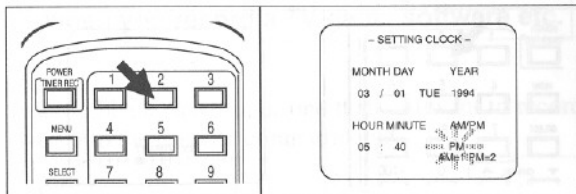
**10**

Press MENU or SELECT button to start the clock.

Although seconds are not displayed, they begin counting from 00 when you press MENU or SELECT button. Use this feature to synchronize the clock with the correct time.

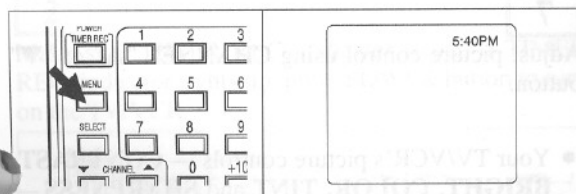

- This unit has a built in calendar up to the year 2008.

TO CHANGE CLOCK SETTING

If you want to change the clock,

- 1) Follow steps [2] and [3] on page 16.
- 2) Select desired digit using SELECT button or ADD/DELETE button.
- 3) Enter correct numbers using number button.
- 4) Press MENU button to return to TV mode.

TO CHANGE THE LANGUAGE

1

Press MENU button on the remote control.

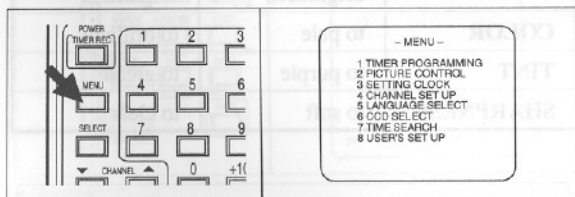
**2**

Select item 5 (LANGUAGE SELECT) using number button.

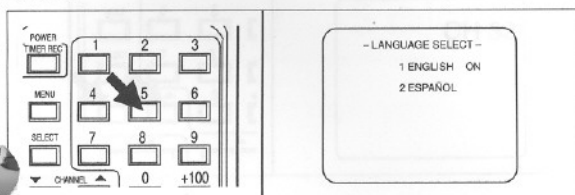
**3**

Select item 1 (ENGLISH) or 2 (ESPAÑOL=SPANISH) using number button.

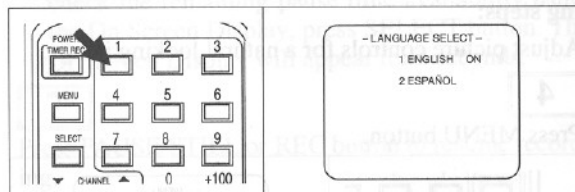
**4**

Press MENU button to return to TV mode.

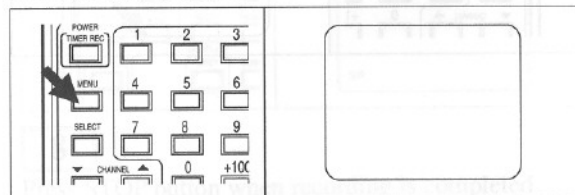

TV OPERATION

1

Press POWER button to turn on the TV/VCR.

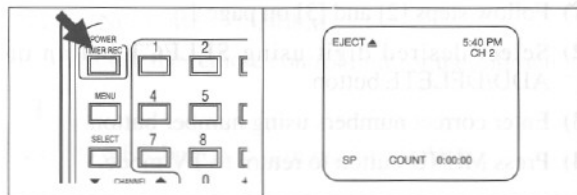

2

Select the desired channel using number button or CHANNEL "▲" or "▼" button.

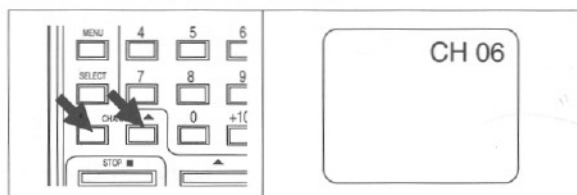

3

Adjust the VOLUME to desired listening level using the VOLUME "▲" or "▼" button.

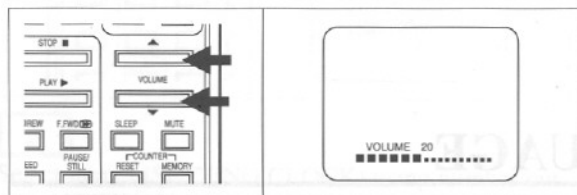

PICTURE ADJUSTMENT

You must use the remote control unit for the following steps:

Adjust picture controls for a natural looking image.

4

Press MENU button.

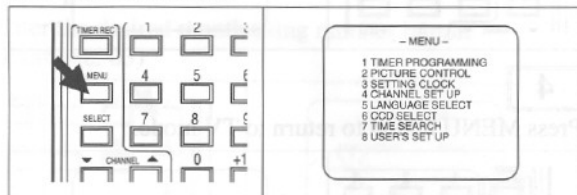

5

Select item 2 (PICTURE CONTROL) using number button.

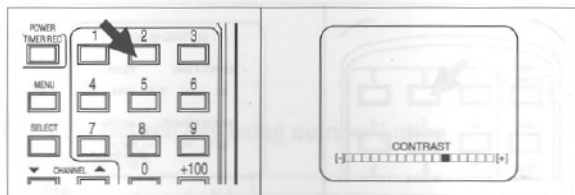

6

Press SELECT button repeatedly until desired control is displayed.

Each time you press the SELECT button, **CONTRAST, BRIGHT, COLOR, TINT** and **SHARPNESS** will appear on the screen in sequence.

7

Adjust picture control using CHANNEL "▲" or "▼" button.

- Your TV/VCR's picture controls — **CONTRAST, BRIGHT, COLOR, TINT** and **SHARPNESS** — are preset to the default position. This is usually best, but if you need to make any further adjustments, use the following chart as a guide.

	CHANNEL ▼	CHANNEL ▲
CONTRAST	to decrease contrast	to increase contrast
BRIGHT	to decrease brightness	to increase brightness
COLOR	to pale	to brilliant
TINT	to purple	to green
SHARPNESS	to soft	to clear

Note: When setting the PICTURE CONTROL, the GAME MODE will be automatically set to OFF.

VIEWING AND RECORDING THE SAME PROGRAM

You can only watch the same TV program that is being recorded.

NOTE: You may not have good results when you record a TV game software etc.

1

Insert a blank cassette, or one that you want to record over, into the cassette compartment.

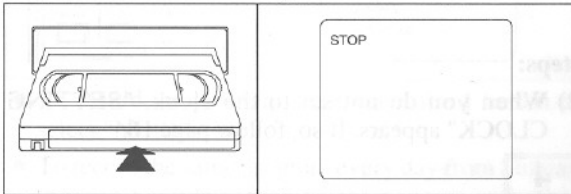

- If necessary, rewind or fast forward the tape to the point you want to start recording.

2

Make sure **TIMER REC.** indicator is off. If **TIMER REC.** indicator lights up, press **POWER** button to turn on the TV/VCR.

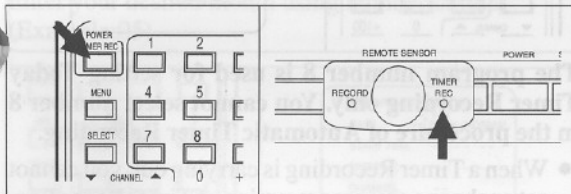

3

Press **SPEED** button on the remote control repeatedly until the desired recording speed is displayed (**SP/LP/SLP**). (Example : **SP**)

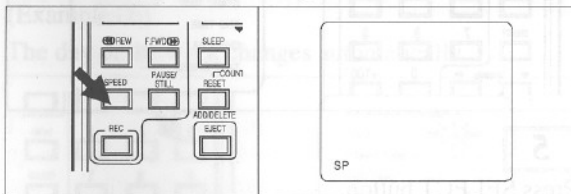

4

Select the program to be recorded by using the number button or the **CHANNEL "▲"** or **"▼"** button.

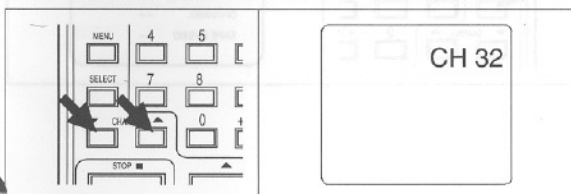

5

Press **REC** button.

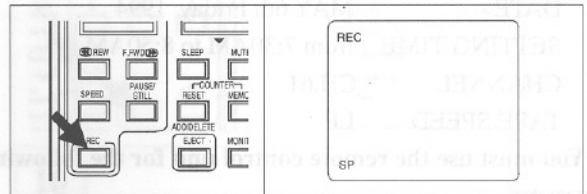

To skip some material while you are recording:

6

Press **PAUSE/STILL** button on the remote control to temporarily stop recording.

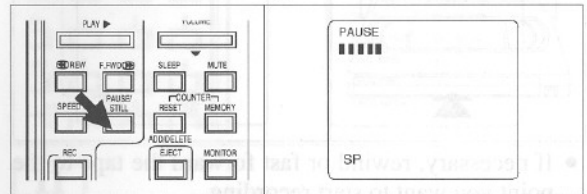

Notes:

- If the TV/VCR is left in the Pause/Still mode for more than 5 minutes while Recording mode, it will automatically switch to the Recording mode. When in the Pause/Still mode, a display showing 5 "■" marks will appear on the screen. Each "■" mark represents one minute of Pause time. You may refer to this display for remaining pause time available.
- If "CLOSED CAPTION [ON]" is selected from the "CCD SELECT" menu, the On Screen Display will appear for 5 seconds, then disappear. If you want to check the remaining pause time availability using the On Screen Display, press **SELECT** button. The On Screen Display will appear for 5 seconds.

7

Press **PAUSE/STILL** or **REC** button to resume recording.

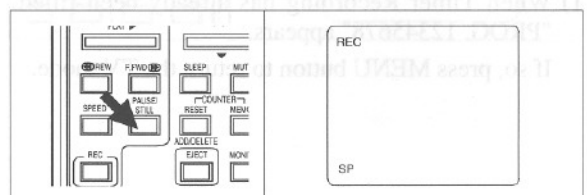

8

Press **STOP** button when recording is completed.

AUTOMATIC TIMER RECORDING

You may set the TV/VCR to record while you are away. You can set seven events to record on a specific day, daily or weekly within a 1 year period.

Be sure the clock is set to the correct time and date before setting the timer.

In the example below, the timer is being set to record:

DATE MAY 6th Friday, 1994
 SETTING TIME from 7:30AM to 8:50AM
 CHANNEL CH.61
 TAPE SPEED LP

You must use the remote control unit for the following steps:

1

Insert a blank cassette, or one that you want to record over, into the cassette compartment.

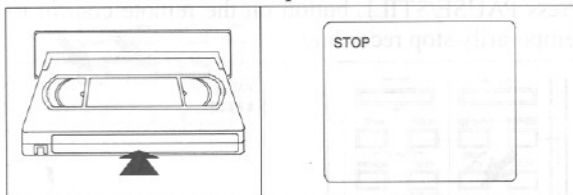

- If necessary, rewind or fast forward the tape to the point you want to start recording.

2

Press MENU button.

The main menu display appears on the TV/VCR screen.

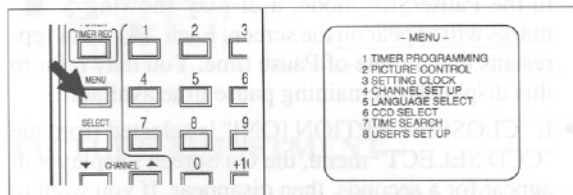

3

Select item 1 (TIMER PROGRAMMING) using number button.

The program number which is not set up flashes.

Notes:

- 1) When Timer Recording has already been filled, "PROG. 12345678" appears.
 If so, press MENU button to return the TV mode.

- 2) When you do not set to the clock, "SETTING CLOCK" appears. If so, follow page 16.

4

Enter your desired program number using number button. (Example: 4)

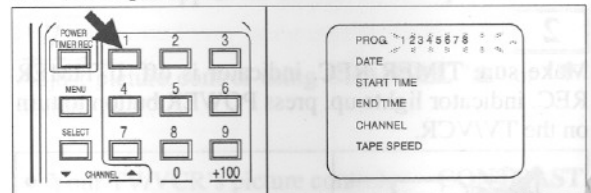

The program number 8 is used for setting Today Timer Recording only. You cannot select number 8 in the procedure of Automatic Timer Recording.

- When a Timer Recording is carrying out, you cannot set or change any programming of Timer Recording. Press POWER button to record continuously.

5

Press SELECT button.

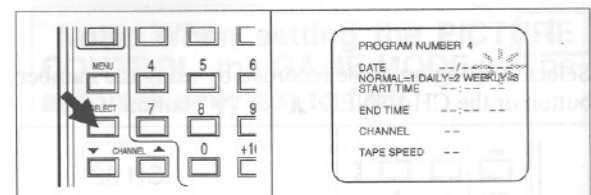

6

Enter 1 to select NORMAL, enter 2 to select DAILY or enter 3 to select WEEKLY using number button.
(Example: 1→NORMAL)

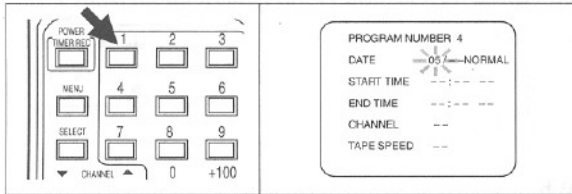

- To record the program once, press the 1 button to select "NORMAL".
- To record the same program every day from Sunday through Saturday (such as soap operas and other daily serials), press the 2 button to select "DAILY".
- To record the same program every week on the same day (such as every Saturday), press the 3 button to select "WEEKLY".

7

Enter your desired month using number button.
(Example:05)

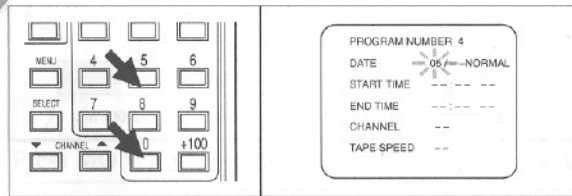
**8**

Enter your desired day using number button.
(Example:06)

The day of the week changes automatically.

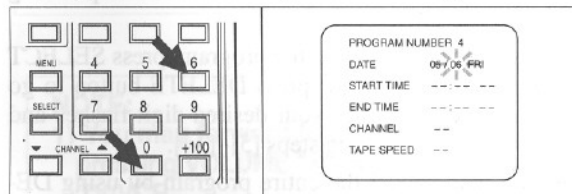
**9**

Enter your desired start time hour using number button.
(Example:07)

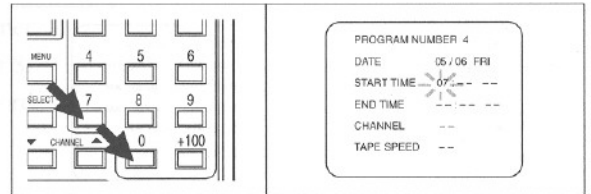
**10**

Enter your desired start time minute using number button.
(Example:30)

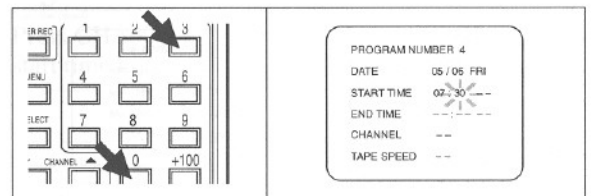
**11**

Enter 1 to select AM or enter 2 to select PM using number button.
(Example: 1→AM)

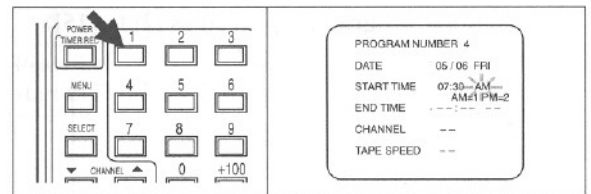
**12**

Repeat steps [9]-[11] to set the end time.
(Example: 08:50AM)

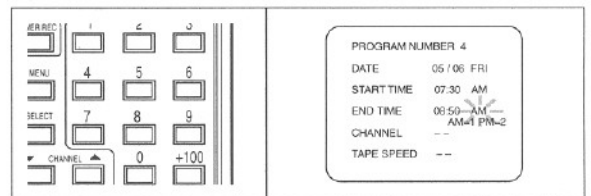

13

Enter your desired channel using number button.
(Example: 61)

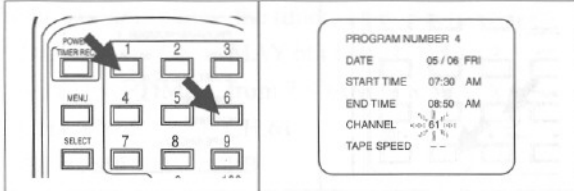
**14**

Enter 1 to select SP, enter 2 to select LP or enter 3 to select SLP using number button. (Example: 2→LP)

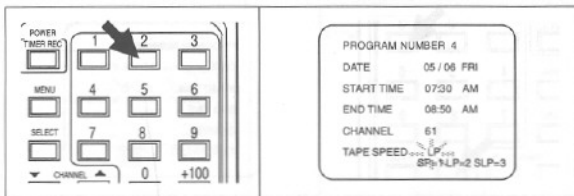
**15**

Press MENU or SELECT button on the remote control unit. Program 4 is now completed.

To set another program, repeat steps [2] to [15].

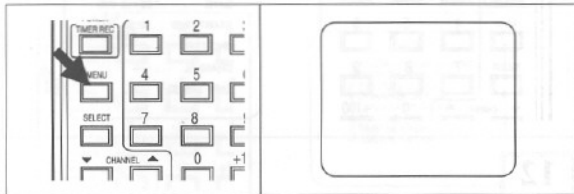
**16**

Press POWER button on the TV/VCR or on the remote control unit. The TIMER REC. indicator lights up.

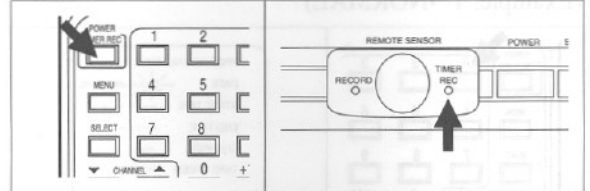

While watching TV, "TIMER REC STANDBY" starts flashing on the TV/VCR screen 2 minutes before the programmed start time.

You must turn off the TV/VCR to activate automatic timer recording.

Note: When the programs overlap, the earlier program has priority.

If you programmed as per the above illustration the timer recording would be carried out as follows:

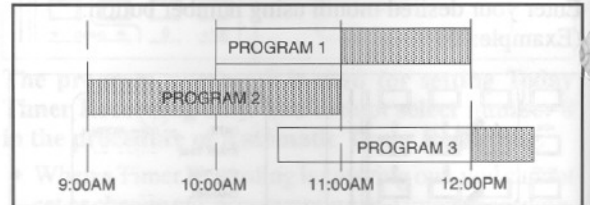

9:00AM - 11:00AM for PROGRAM 2

11:00AM - 12:00PM for PROGRAM 1

12:00PM - for PROGRAM 3

TO CORRECT OR DELETE A PROGRAM

- Press DELETE button to go back one step during steps [5]~[14].
- If you finished setting the program, press SELECT button repeatedly (or press DELETE button to go back one step) until your desired digit flashes and reset program during steps [5]~[14].
- You may cancel the entire program by using DELETE button at step [4].

TODAY TIMER RECORDING

You may set the TV/VCR to record one program within 24 hours by simply pressing MONITOR button on the TV/VCR.

It is easy for you to record today's TV program.

Power must be on to set Today Timer.

Clock must be set to the correct time before setting the timer.

Today Timer Recording is memorized to program number 8.

In the example below, the Today Timer is being set to record:

SETTING TIME from 10:00PM to 11:00PM

CHANNEL CH10

TAPE SPEED SP

Current time is 8:00PM.

This function is not operative using the remote control.

1

Insert a blank cassette, or one that you want to record over, into the cassette compartment. If necessary, re-wind or fast forward the tape to the point at which you want to begin recording.

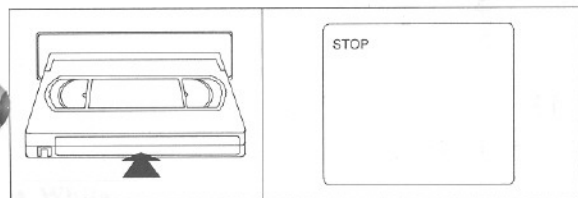

2

Press MONITOR button on the TV/VCR.

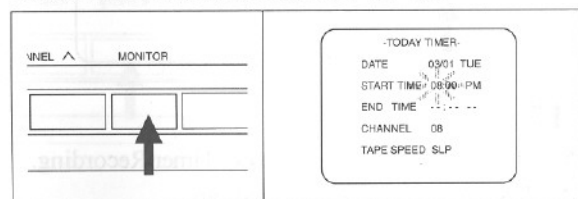

NOTE:

- 1) You may forward to the next step by pressing VOLUME " \wedge " button on the TV/VCR.
- 2) When you press VOLUME " \vee " button on the TV/VCR, all selections will be erased and the TV/VCR screen will return to the initial display (step [2]).

3

Press CHANNEL " \wedge " or " \vee " button until your desired start time hour is displayed. (Example: 10)

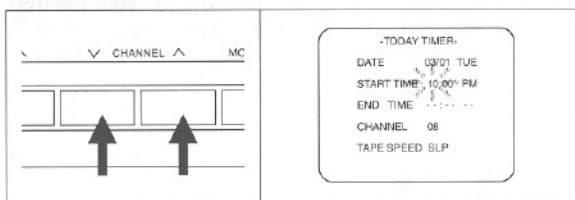

- Press VOLUME " \wedge " button.

4

Press CHANNEL " \wedge " or " \vee " button until your desired start time minute is displayed. (Example: 00)

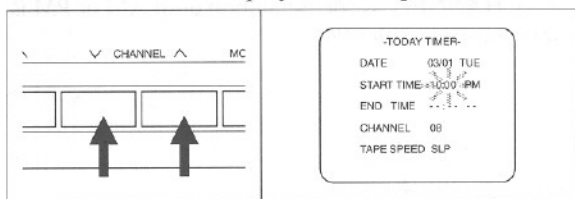

- Press VOLUME " \wedge " button.

5

Press CHANNEL " \wedge " or " \vee " button until AM or PM is displayed. (Example: PM)

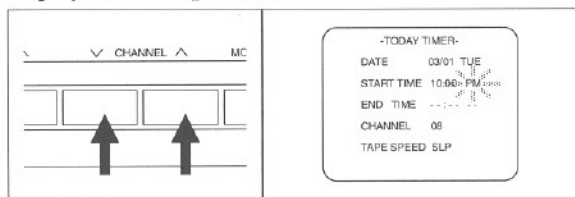

- Press VOLUME " \wedge " button.

NOTE: TODAY TIMER RECORDING can not be programmed by remote control. This function can only be programmed from the main unit.

6

Press CHANNEL " \wedge " or " \vee " button until your desired end time hour is displayed. (Example: 11)

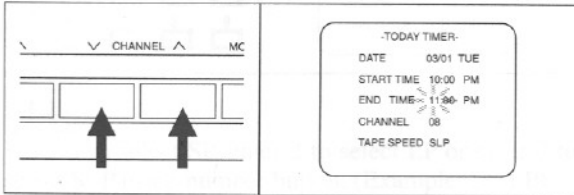

- Press VOLUME " \wedge " button.

7

Press CHANNEL " \wedge " or " \vee " button until your desired end time minute is displayed. (Example: 00)

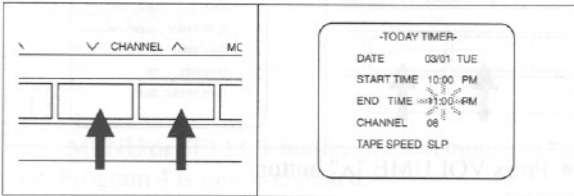

- Press VOLUME " \wedge " button.

8

Press CHANNEL " \wedge " or " \vee " button until AM or PM is displayed. (Example: PM)

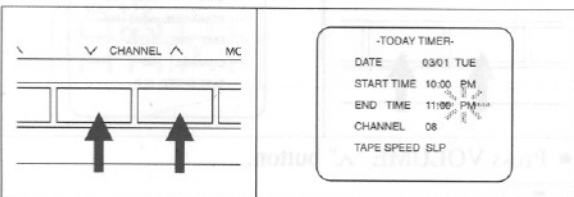

- Press VOLUME " \wedge " button.

9

Press CHANNEL " \wedge " or " \vee " button until your desired channel number is displayed. (Example: 10)

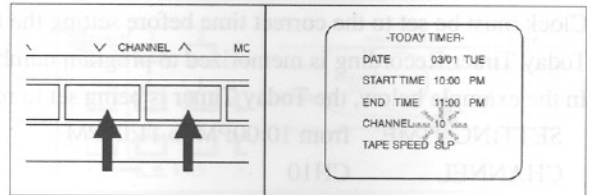

- Press VOLUME " \wedge " button.

10

Press CHANNEL " \wedge " or " \vee " button until your desired tape speed is displayed. (Example: SP)

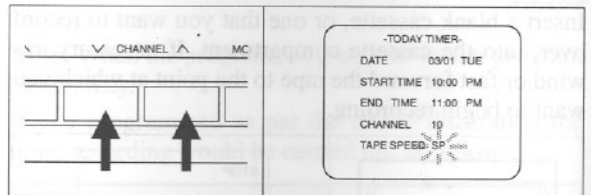

11

Press MONITOR button.

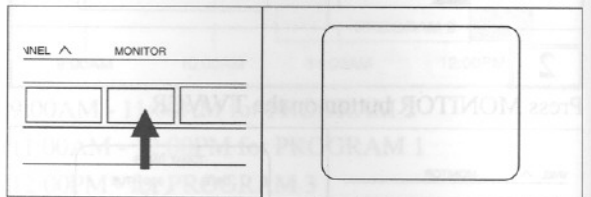

12

Press POWER button to set Today Timer Recording. The TIMER REC. indicator lights up.

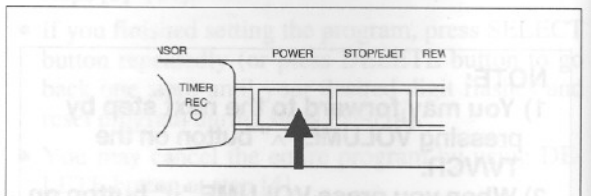

While watching TV, "TIMER REC STANDBY" starts flashing on the TV/VCR screen 2 minutes before the programmed start time.

You must turn off the TV/VCR to activate today timer recording.

When the programs overlap, Today Timer Recording has priority.

If you program as per the illustration the timer recording would be carried out as follows.

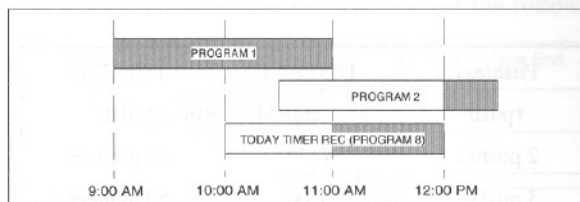

9:00AM-11:00AM for PROGRAM 1

11:00AM-12:00PM for TODAY TIMER REC
(PROGRAM 8)

12:00PM- for PROGRAM 2

TO CANCEL A TODAY TIMER RECORDING

- **While setting a program;** press VOLUME "v" button on the TV/VCR.
- **After setting a program;** (power must be on) First, press MONITOR button. Then, press VOLUME "v" button. Press MONITOR button again to returns to TV mode.
- **While recording is in progress;** press STOP/EJECT button.

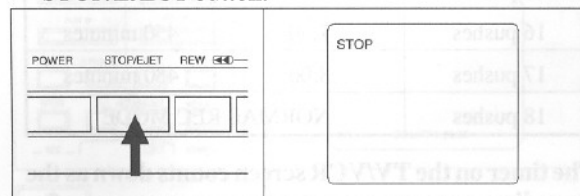

TO CHECK THE START/END TIME

To check the start/end time and channel number, follow steps 1) ~ 4) below.

- 1) Press MENU button on the remote control.
- 2) Select item 1 (TIMER PROGRAMMING) using number button.
- 3) Select program number 8 using number button. "TODAY TIMER" appears on the TV/VCR screen.
- 4) Press MENU button. The TV/VCR screen returns to the TV mode.

HINTS ON AUTOMATIC TIMER RECORDING

- If there is a power failure or if the TV/VCR is unplugged for more than a few seconds, the clock and timer settings will be lost. At this time, the TV/VCR screen will automatically return to the Clock Set mode when you choose the Program Set mode.
- If two timer programs overlap, the one that starts first has priority. When the first program ends, the TV/VCR switches to record the remainder of the second program.
- Make sure the channel you want to record is properly set in advance.
- The erase-prevention tab on the cassette must be in place (or you must put tape over the hole).
Note: A cassette without erase-prevention tab will be ejected when in the Timer Record mode.
- It is not necessary to press REC button for timer recording.
- Recording begins automatically at the set of the Start time.
- If you are recording using the Automatic Timer mode, you may not operate the unit manually, but, you may still stop the recording by using the STOP/EJECT button on the TV/VCR.
Note: STOP button on the remote control unit will not function in this mode.
- If the tape runs out before the end time, the TV/VCR will switch to the Stop mode immediately, and the tape will be ejected.
- If the POWER button is pressed to OFF with no cassette loaded, the TIMER REC. indicator flashes.
- If the erasure protection tab is removed, the cassette will be ejected when the POWER button is pressed to OFF, and the TIMER REC. indicator flashes.
- If the TIMER REC. indicator flashes, insert a tape with the erase-prevention tab intact. The TIMER REC. indicator will illuminate.

TO CHECK TIMER PROGRAMS

To check a timer program that is to be recorded while the TV/VCR is in the Timer Record mode:

- 1) Press POWER button so that the TIMER REC. indicator goes off.
- 2) Follow instructions in steps [2] to [4] on page 20. Information which was set for programming will now appear.

OTR (ONE TOUCH RECORDING)

The One Touch Recording function enables you to record a program simply by using the OTR button on the TV/VCR.

According to the table, simply press OTR button as many times as needed to set the desired recording length. The channel number to be recorded and recording length will be shown on the TV/VCR screen.

This function is not operative using the remote control.

1

Insert a blank cassette, or one that you want to record over, into the cassette compartment.

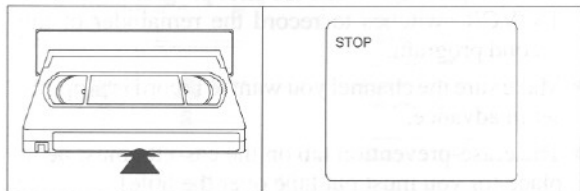

- If necessary, rewind or fast forward the tape to the point you want to start recording.

2

Select the CHANNEL to be recorded.

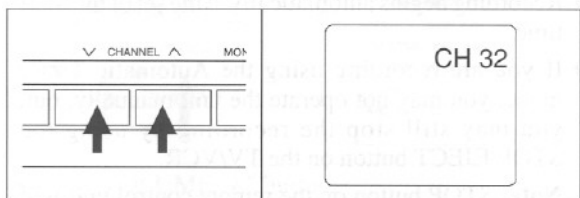

3

Press RECORD/OTR button on the TV/VCR.

(Example: 4 pushes for 90 minutes)

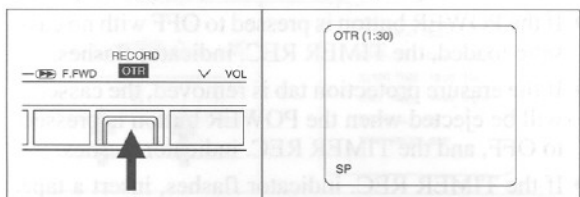

Recording starts immediately when the REC./OTR button is pressed, even if you are watching a TV program.

TO STOP THE OTR OPERATION

Press STOP button on the TV/VCR or remote control.

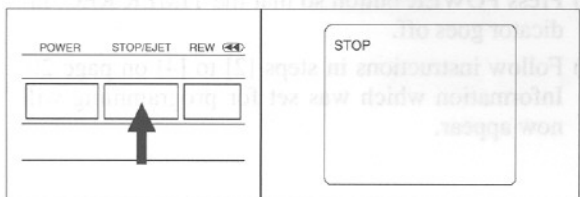

Push(es)	DISPLAY	LENGTH
1 push	NORMAL REC MODE	
2 pushes	0:30	30 minutes
3 pushes	1:00	60 minutes
4 pushes	1:30	90 minutes
5 pushes	2:00	120 minutes
6 pushes	2:30	150 minutes
7 pushes	3:00	180 minutes
8 pushes	3:30	210 minutes
9 pushes	4:00	240 minutes
10 pushes	4:30	270 minutes
11 pushes	5:00	300 minutes
12 pushes	5:30	330 minutes
13 pushes	6:00	360 minutes
14 pushes	6:30	390 minutes
15 pushes	7:00	420 minutes
16 pushes	7:30	450 minutes
17 pushes	8:00	480 minutes
18 pushes	NORMAL REC MODE	

The timer on the TV/VCR screen counts down as the recording progresses.

Notes:

- When you press OTR button, you will extend the recording time by 30 minutes at a time up to 8-hours (or to the end of the tape).
- When the OTR button is pushed 18 times the TV/VCR will record continuously until the end of the tape.
- The recording length time remaining will be displayed on the TV/VCR screen as the recording is started.
- Recording stops when 0:00 is reached.
- Please note that in the SLP mode maximum recording time, assuming the tape is started of the beginning, is 8 hours using T-160 (or 6 hours using T-120).

COUNTER MEMORY

The Counter Memory can be used during rewind or fast forward to automatically stop the tape when the count reaches a preset memory position at approx. 0:00:00 reading.

For example, this feature can be used to return the tape to a pre-selected position immediately after recording, or to repeatedly playback a certain portion of a tape.

You must use the remote control unit for the following steps:

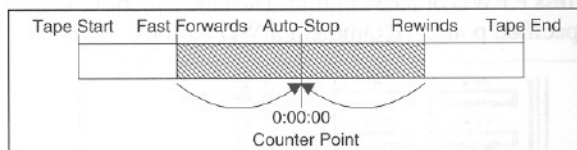

1

If the count is displayed on the TV/VCR screen, skip step [1].

If the count is not displayed, press SELECT button so that the Count mode appears on the TV/VCR screen.

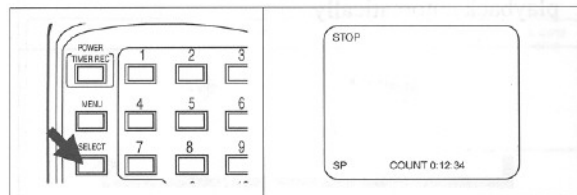

2

Press COUNTER RESET button. The count resets to 0:00:00.

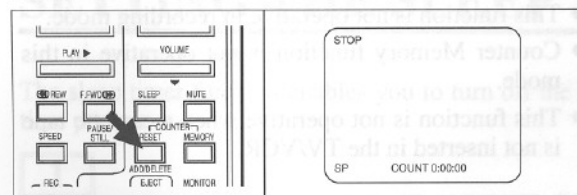

3

Press COUNTER MEMORY button.

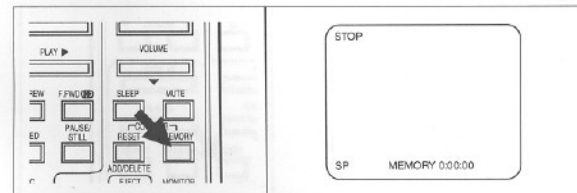

4

Press SELECT button repeatedly until the TV/VCR screen returns to TV mode.

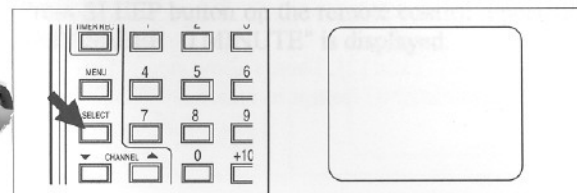

5

Press REC or PLAY button.

6

Press STOP button when recording or playback is completed.

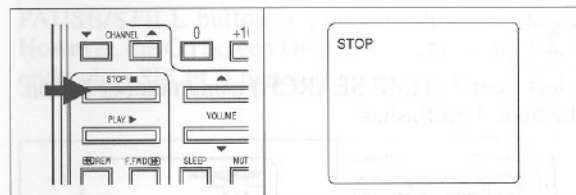

7

Press SELECT button so that the Count mode appears.

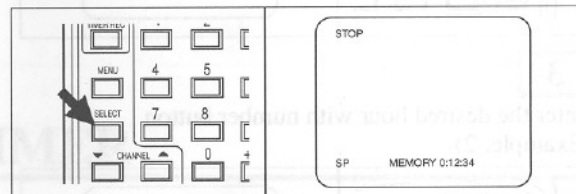

8

Press REW button. The tape will automatically stop when the count returns to approx. 0:00:00.

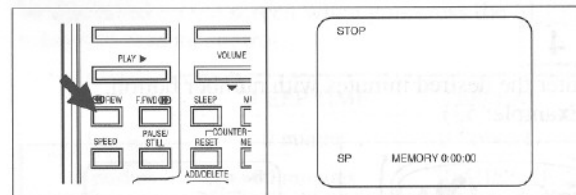

TO CANCEL THE COUNTER MEMORY

When the counter appears on the display, press COUNTER MEMORY button so that "COUNT" appears on the TV/VCR screen.

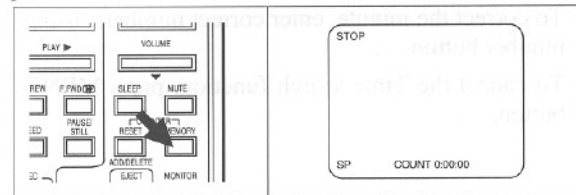

TIME SEARCH

The Time Search function makes it possible to quickly advance the tape from any position by entering the exact desired amount of playback time of the part that you want to skip.

You must use the remote control unit for the following steps:

1

Press the MENU button.

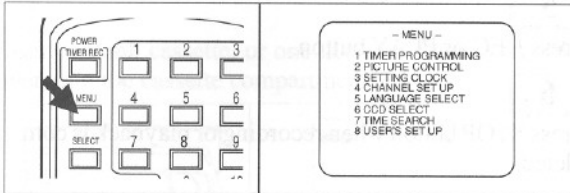

2

Select item 7 (TIME SEARCH) using number button. The hour digit flashes.

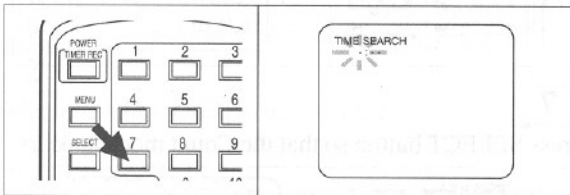

3

Enter the desired hour with number button. (Example: 2)

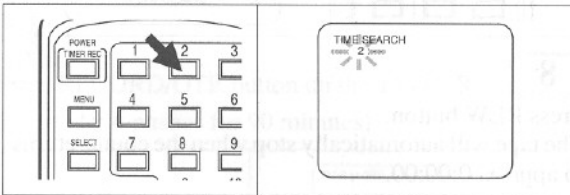

4

Enter the desired minutes with number button. (Example: 53)

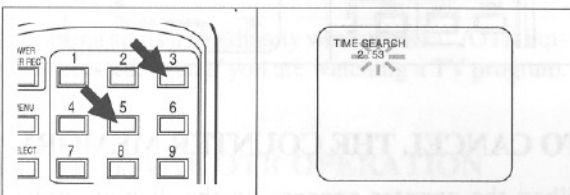

- To correct the hour, press DELETE button and repeat steps [3] and [4].
- To correct the minute, enter correct numbers using number button.
- To cancel the Time search function, press MENU button.

5

Press F.FWD or REW button. The tape will move to the specified point. (Example: F.FWD button)

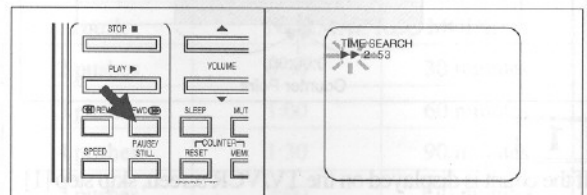

- The time counts down as the searching progresses. When 0:00 is reached, the tape will start playback automatically.



Notes:

- Time search can be set up to 9:59.
- This function is not operative in recording mode.
- Counter Memory function is not operative in this mode.
- This function is not operative when a cassette tape is not inserted in the TV/VCR.

TO FINISH THE TIME SEARCH MODE

Press STOP button on the TV/VCR or remote control unit.

CHECKING THE COUNT, CLOCK AND CHANNEL NUMBER

To check the Count, Clock and Channel number on the TV/VCR screen, press the SELECT button on the remote control.

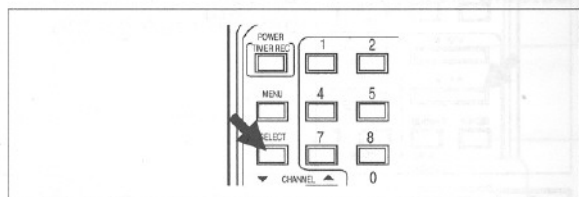

Each time you press the SELECT button on the remote control, the TV/VCR screen will change as follows:

When the Closed Caption mode is OFF:

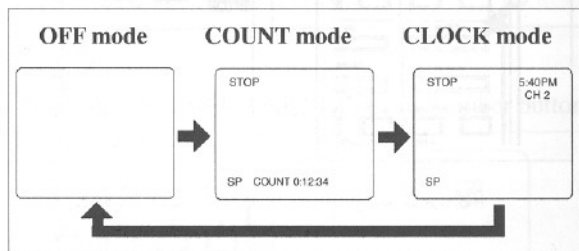

When the Closed Caption mode is ON:

The On Screen Display will disappear after 5 seconds.

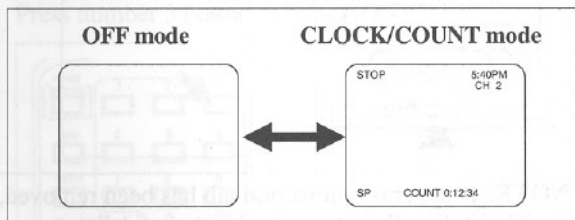

This is true even if MUTE button is pressed, or PAUSE/STILL button is pressed while recording. However, the On Screen Display will appear for 5 seconds when SELECT button is pressed.

SETTING THE SLEEP TIMER

The sleep timer function enables you to turn off the TV/VCR without using the POWER button after a desired time period.

1

Press SLEEP button on the remote control repeatedly until desired SLEEP time is displayed.
(Example: 30MINUTE)

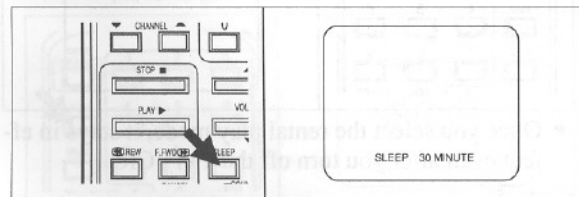

The turn off time can be determined by the number of times you press the SLEEP button. (The sleep timer will be displayed on the screen when you press the SLEEP button on remote control.)

	SLEEP TIME	DISPLAY
1 push	0 minute	0 MINUTE
2 pushes	30 minutes	30 MINUTE
3 pushes	60 minutes	60 MINUTE
4 pushes	90 minutes	90 MINUTE
5 pushes	120 minutes	120 MINUTE
6 pushes	0 minute	0 MINUTE

TO CANCEL THE SLEEP TIMER

Press SLEEP button on the remote control repeatedly until "SLEEP 0 MINUTE" is displayed.

PLAYBACK

1

Insert a cassette into the cassette compartment.

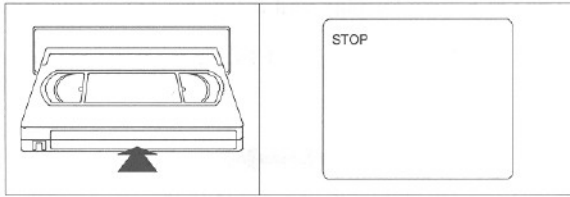

NOTE: If the erase-protection tab has been removed, the TV/VCR will start playback automatically.

2

If playback does not begin automatically, press PLAY button.

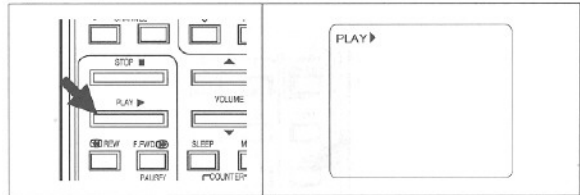

3

Press STOP button when playback is completed.

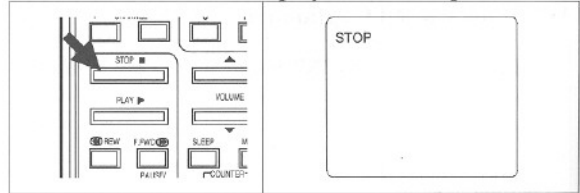

RENTAL PLAY

This function enables you to improve the picture quality when playing back worn cassettes such as those rented from a video shop.

Before playback, follow steps below.

You must use the remote control unit for the following steps:

1

Press MENU button.

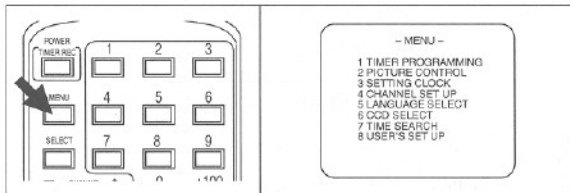

2

Select item 8 (USER'S SET UP) using number button.

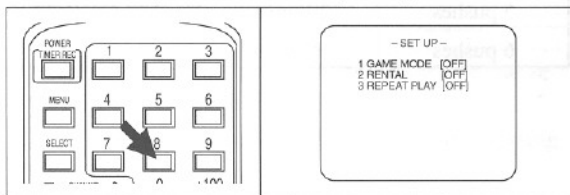

3

Press number 2 button to select [ON].

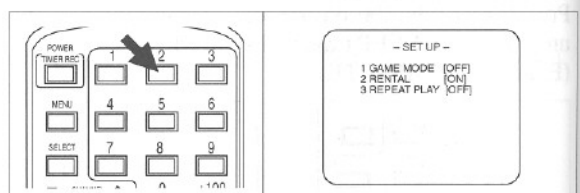

- Once you select the rental play mode, it stays in effect even after you turn off the TV/VCR.

4

First press MENU button, then press PLAY button to start the Rental play.

TO EXIT THE RENTAL PLAY MODE

Repeat steps [1] and [2]. Then, follow step [3], to select [OFF]. Press MENU button to return to TV mode.

AUTO REPEAT PLAYBACK

The TV/VCR has an auto repeat function that allows you to repeat a tape indefinitely without using the PLAY button. Before playback, follow steps below. You must use the remote control unit for the following steps:

NOTE: If the "COUNTER MEMORY" is activated, the tape will automatically stop when the count returns to approx. 0:00:00 during Auto Rewind.

1

Press MENU button.

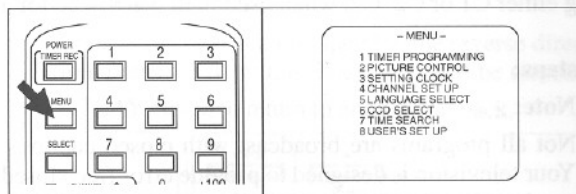

2

Select item 8 (USER'S SET UP) using number button.

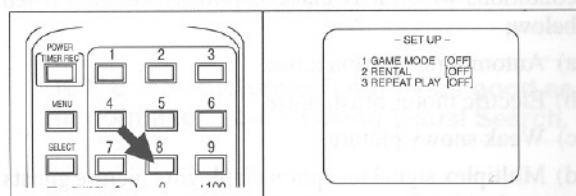

3

Press number 3 button to select [ON].

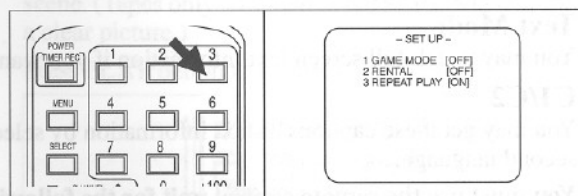

- Once you select the Repeat Play mode, it stays in effect even after you turn off the TV/VCR.

4

Press PLAY button to start the Repeat Play.

- If the rental play function is set ON, the "RENTAL PLAY ►" display has priority.

TO EXIT THE REPEAT PLAY MODE

Press STOP button and repeat steps [1] and [2]. Then, follow step [3], but select [OFF]. Press MENU button to return to TV mode.

NOTE: Any buttons except POWER and STOP buttons do not work during Auto Repeat Playback. Always set the Auto Repeat Playback function off.

GAME MODE

This function enables you to adjust the picture to making suitable for use with a TV GAME.

You must use the remote control unit for the following steps:

1

Press MENU button.

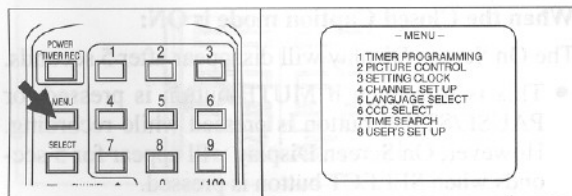

2

Select item 8 (USER'S SET UP) using number button.

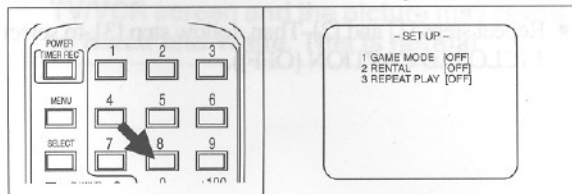

3

Press number 1 button to select [ON].

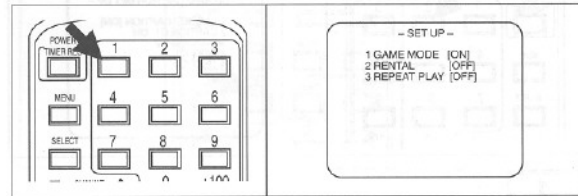

TO CANCEL THE GAME MODE

- Repeat steps [1] and [2]. Then, follow step [3], to select [OFF]. Press MENU button to return to TV mode.

OR

- Set the PICTURE CONTROL. (See page 18.) The GAME MODE will then automatically be turned to OFF.

CLOSED CAPTION SYSTEM

You may view specially labeled (cc) TV programs, movies, news, prerecorded tapes, etc. with either a dialogue caption or text display added to the program.

Caption Mode

You may watch dramas, movies and news etc. with captioning the dialogues and the contents of news if you want by choosing the caption mode.

Text Mode

You may watch full screen text information if you want by choosing the text mode.

C1/C2

You may get these captions or text information by selecting either C1 or C2. C2, when used, will usually be for a second language.

You must use the remote control unit for the following steps:

1

Press the MENU button.

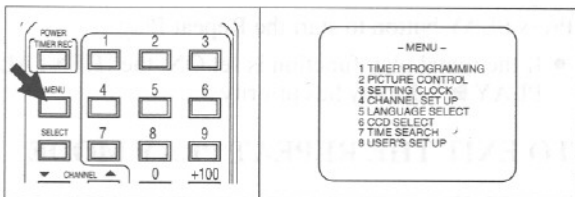

2

Select item 6 (CCD SELECT) using number button.

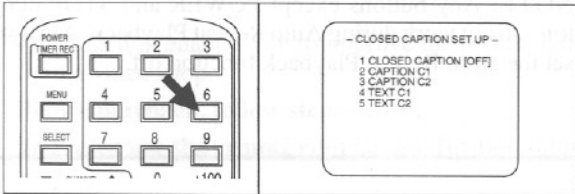

3

Press number buttons to change the Caption mode.
(Example: CAPTION C1)

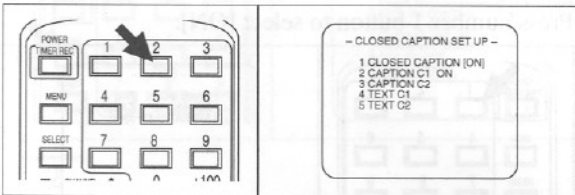

4

Press the MENU button. The selected caption broadcast appears on the TV/VCR screen.

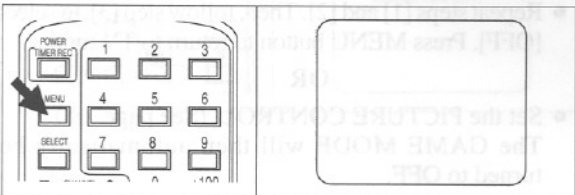

Note:

Not all programs are broadcast with closed captions. Your television is designed to provide error free closed captions from high quality antenna, cable and VCR signals. Conversely, poor quality signals are likely to result in caption errors or no captions at all. Common signal conditions which may cause captions errors are listed below;

- Automobile ignition noise.
- Electric motor brush noise.
- Weak snowy picture.
- Multiplex signal reception displaying picture ghosts or airplane flutter.
- Playback of poorly recorded or worn VCR tapes.
- Still mode or Slow motion playback.
- If you see this screen!!

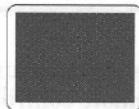

If your TV displays a black box on the screen, this means that your TV is set to TEXT mode. To clear screen, select CAPTION C1, C2 or CLOSED CAPTION [OFF].

When the Closed Caption mode is ON:

The On Screen Display will disappear after 5 seconds.

- This is true even if MUTE button is pressed, or PAUSE/STILL button is pressed while recording. However, On Screen Display will appear for 5 seconds when SELECT button is pressed.

TO CANCEL THE CLOSED CAPTION SYSTEM

- Repeat steps [1] and [2]. Then, follow step [3], to select 1 (CLOSED CAPTION [OFF]).

SPECIAL FEATURES

VISUAL SEARCH (SP/LP/SLP MODE)

You may view a video tape at a high speed in either a forward or reverse direction. This feature is useful in finding or skipping over a particular scene on a tape.

Forward Direction:

When in the Play mode, press F.FWD button to view the tape at a fast speed in the forward direction. The sound will be muted.

Reverse Direction:

To view the tape at a fast speed in the reverse direction, press REW button. The sound will be muted.

Press PLAY button to return to normal playback.

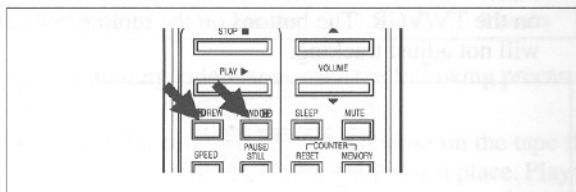

NOTE: The picture will not be as good as in normal playback during Visual Search.

SUPER HIGH SPEED SEARCH (LP/SLP MODE)

For Visual Search in super high speed:

- 1) Press either F.FWD or REW button while the unit is in the Play mode.
- 2) Release button.
- 3) Depress it again. The unit will now search in super high speed.

Press PLAY button to return to normal playback.

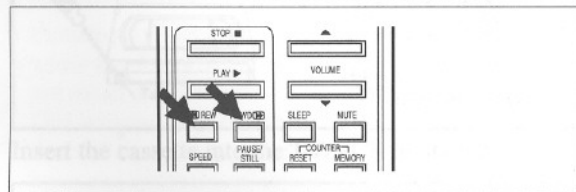

NOTE: Tapes recorded in the LP or SLP mode will display a noise bar on the TV/VCR screen and the picture may revert to Black and White. This is normal.

STILL PICTURE DURING PLAYBACK

If you press PAUSE/STILL button during the Play mode, the picture will "freeze" on the TV/VCR screen.

You may use this feature to study details of a particular scene. (Tapes only recorded in the SLP mode will show a clear picture.)

Press PLAY button to continue playback.

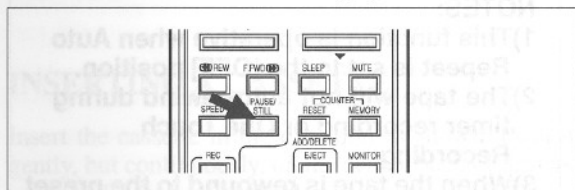

NOTE: The TV/VCR will automatically switch to the Stop mode if it is left in the Pause/Still mode for more than five minutes.

NOISE CANCELLING

If you use the PAUSE/STILL button to freeze the picture during playback with tapes recorded in the SLP mode, usually there will be video "noise bars" on the TV/VCR screen. This is normal, however, this TV/VCR has a special feature that allows you to reposition or reduce the lines. Each time you press PAUSE/STILL button the lines will change position on the TV/VCR screen. This enables you to see the picture in its entirety without distracting noise lines.

If the tape was originally recorded in the SP or LP mode, the still picture may, in addition to the "noise bars", revert to black and white.

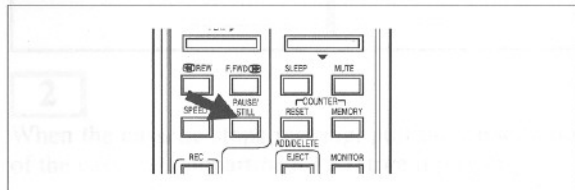

AUTO REWIND-EJECT

When the end of a tape is reached during recording, playback, or fast-forward, the tape will automatically rewind to the beginning (or to the 0:00:00 count reading if the memory function is activated), eject, and the TV/VCR turns off.

NOTES:

- 1) This function is operative when Auto Repeat is set to the [OFF] position.
- 2) The tape will not auto-rewind during timer recording or One Touch Recording.
- 3) When the tape is rewound to the preset memory position or the REW button is pressed during Auto Rewind, the tape will not eject and TV/VCR will not turn off.

TRACKING ADJUSTMENT

- Tracking adjustment will be set automatically (Digital Tracking function) when you start playback.
- When playing pre-recorded tapes or tapes recorded on units other than your own, noise lines (black and white streaks) may appear on the playback picture. If this occurs, adjust the tracking control by pressing CHANNEL "▲" or "▼" button until the streaks disappear. To return to the DTR function, stop the tape once and start playback again.
- To set center position, press both CHANNEL "▲" and "▼" button at the same time.
Note: This function is controlled only by the buttons on the TV/VCR. The buttons on the remote control will not adjust tracking.



DEGAUSSING

Magnetism from nearby appliances might affect the color of the TV picture.

If this happens, move this unit away from the appliance. If the color is still not correct, disconnect power cord from AC outlet then reconnect it after 30 minutes.

VIDEO CASSETTE

This TV/VCR will operate with any cassette that has the VHS mark. For best results we recommend the use of high-quality tapes.

- Do not use poor quality or damaged tapes.

The table below shows the recording/playback time using a T-60, T-120 or T-160 tape in the SP, LP or SLP mode.

MODE	CASSETTE		
	T-60	T-120	T-160
SP Mode	1 hour	2 hours	2-2/3 hours
LP Mode	2 hours	4 hours	5-1/3 hours
SLP Mode	3 hours	6 hours	8 hours

When handling video tapes, take the following precautions:

- Avoid moisture, which can condense on the tape if it is moved from a cold place to a warm place. Playing a tape that has moisture in it will damage the tape and your TV/VCR. Before using a tape with these conditions, wait until the tape has warmed to room temperature and the moisture has evaporated.
- Avoid extreme heat, high humidity and magnetic fields.
- Do not tamper with the cassette mechanism.
- Do not touch the tape with your fingers.

ERASE PREVENTION

You may prevent accidental erasing of a tape by breaking off the tab on the back edge of the cassette. If you decide to record on the tape again, cover the hole with transparent tape.

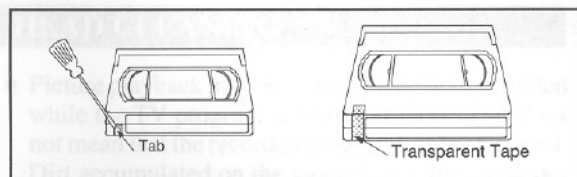

Insert the cassette into the TV/VCR as shown.

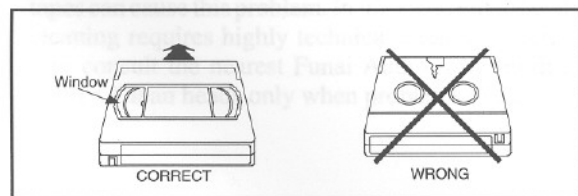

Store the cassette in its case as shown.

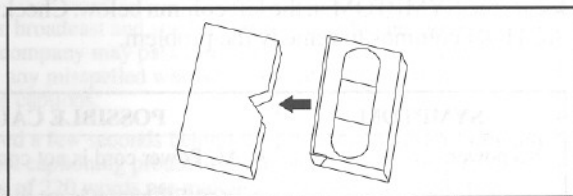

INSERTING A CASSETTE

Insert the cassette in the direction as shown. Push in gently, but continuously, on the center-back of the cassette until it is drawn completely into the TV/VCR.

The TV/VCR will automatically turn on when the cassette is properly inserted.

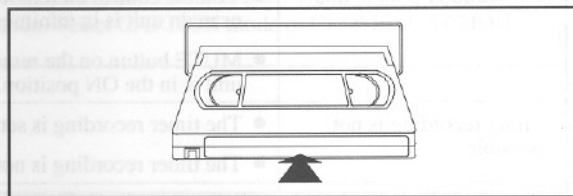

REMOVING A CASSETTE

1

Press EJECT button on the TV/VCR or on the remote control unit.

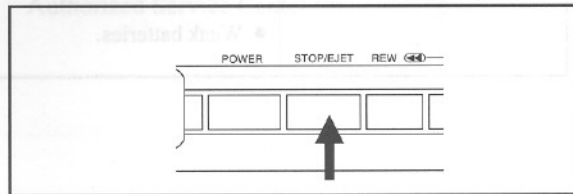

2

When the cassette stops moving, pull the cassette out of the cassette compartment and store it properly.

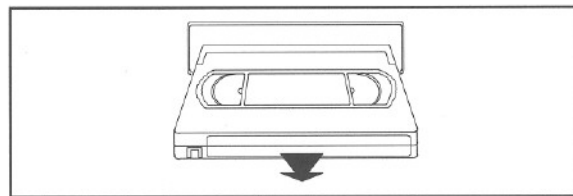

TROUBLESHOOTING GUIDE

If you have followed the instructions contained in this manual and have difficulty in operating your TV/VCR, locate the SYMPTOM in the left column below. Check the corresponding POSSIBLE CAUSE and CORRECTIVE ACTION columns to remedy the problem.

SYMPTOM	POSSIBLE CAUSE	CORRECTIVE ACTION
No power.	<ul style="list-style-type: none"> • AC Power cord is not connected. • POWER button is set to OFF. 	<ul style="list-style-type: none"> • Connect AC power cord to AC outlet. • Set the POWER button to ON.
No picture and sound.	<ul style="list-style-type: none"> • TV/VCR is not plugged into an active AC outlet. • Antenna is not connected. • No channel in memory. 	<ul style="list-style-type: none"> • Plug power cord into an active AC outlet. • Check antenna connection. • Program tuner's memory.
No picture or poor picture on TV/VCR.	<ul style="list-style-type: none"> • Direction or condition of antenna is not adequate. • Picture control is not adequate. 	<ul style="list-style-type: none"> • Adjust direction or replace antenna. • Adjust picture controls.
No sound or poor sound.	<ul style="list-style-type: none"> • Volume control on remote control unit or main unit is in minimum position. • MUTE button on the remote control unit is in the ON position. 	<ul style="list-style-type: none"> • Adjust volume control on remote control unit or set. • Press MUTE button.
Timer recording is not possible.	<ul style="list-style-type: none"> • The timer recording is set incorrectly. • The timer recording is not set to ON. 	<ul style="list-style-type: none"> • Set the timer recording correctly. • Set the timer recording to ON.
Cannot go to Record mode.	<ul style="list-style-type: none"> • The erase-prevention tab on cassette is missing. 	<ul style="list-style-type: none"> • Place transparent tape over missing erase-prevention tab.
Playback picture is partially noisy.	<ul style="list-style-type: none"> • The TRACKING control is not set correctly. 	<ul style="list-style-type: none"> • Adjust TRACKING control for better picture.
Noise in picture on playback.	<ul style="list-style-type: none"> • Video heads are dirty. 	<ul style="list-style-type: none"> • Head cleaning is necessary, consult the nearest Funai Service Center.
No operation by infrared Remote Control.	<ul style="list-style-type: none"> • No power to TV/VCR. • Weak batteries. 	<ul style="list-style-type: none"> • Make sure the AC cord is connected to an AC outlet. • Check the batteries in infrared Remote Control.



CLOSED CAPTION PROBLEM	POSSIBLE REMEDY
My TV/VCR is showing captions that are misspelled.	You are watching a live broadcast and spelling errors made by the closed captioning production company may pass through uncorrected. A prerecorded program will not show any misspelled words because of the normal time available for editing the captions.
My TV/VCR will not show the text in its entirety or there is a delay of what is being said.	Captions that are delayed a few seconds behind the actual dialogue are common for live broadcasts. Most captioning production companies can display a dialogue to a maximum of 220 words per minute. If a dialogue exceeds that rate, selective editing is used to insure that the captions remain up-to-date with the current TV/VCR screen dialogue.
My captions are scrambled with white boxes on the TV/VCR screen.	Interference caused by building, power lines, thunderstorms, etc. may cause scrambled or incomplete captions to appear.
My program guide listed a TV show as being closed captioned but none of the captions were displayed.	Broadcasters may at times use a time compression process to speed up the actual program so that additional advertising time can be given. Since the decoder cannot read the compressed information, captions will be lost.
My prerecorded video tape does not show any captions. The tape box mentions it being closed captioned.	The video tape was either an illegal copy or the tape duplicating company accidentally left out the captioning signals during the copying process.
My TV screen shows a black box on contain channels.	You are in the TEXT mode. Select CAPTION mode or CLOSED CAPTION [OFF].

MAINTENANCE

CABINET CLEANING

- Wipe the front panel and other exterior surfaces of the TV/VCR with a soft cloth immersed in lukewarm water and wrung dry.
- Never use a solvent or alcohol. Do not spray insecticide liquid near the TV/VCR. Such chemicals may cause damage and discoloration to the exposed surfaces.

HEAD CLEANING

- Picture playback may become blurred or interrupted while the TV program reception is clear. This does not mean that the recorded program has been erased. Dirt accumulated on the video heads after long periods of tape playback, or the usage of rental or worn tapes can cause this problem. In this case, video head cleaning requires highly technical attention, therefore consult the nearest Funai Authorized Service Center. Clean heads only when problems occur.

SERVICING

- Should your TV/VCR become inoperative, do not try to correct the problem by yourself. There are no user-serviceable parts inside. Turn off, unplug the power cord, and take the unit to the nearest Funai Authorized Service Center for servicing.

SPECIFICATIONS

GUIDE

GENERAL SPECIFICATIONS

CRT	: 19 inch in-line gun, 90° deflection tube
Television system	: NTSC-M
Closed caption system	: §15.119/FCC
Recording system	: Rotary two-head helical scan system
Tape width	: 1/2 inch
Tape speed	
SP	: 33.40mm/sec.
LP	: 16.67mm/sec.
SLP	: 11.12mm/sec.
Tuner channel	
TV VHF Low	: #2~#6
TV VHF High	: #7~#13
TV UHF	: #14~#69
CATV	
VHF	: 5A
MID band	: A5~A1, A~I
SUPER band	: J~W
HYPER band	: W+1~W+84

Terminals:

Antenna input	VHF/UHF 75 ohms unbalanced
Video input	RCA connector
Audio input	RCA connector
Earphone	3.5 mm

ELECTRICAL SPECIFICATIONS

Video input level	: 0.5~2.0V _{p-p}
Audio input level	: -15dBs
Video S/N ratio	: More than 46dB
Audio S/N ratio	: More than 43dB

OTHER SPECIFICATIONS

Power requirement	: AC 120V/60Hz
Power consumption	: 85W
Dimensions:	
H	: 19-3/8" (492.5mm)
W	: 19-1/16" (484mm)
D	: 18-1/32" (458mm)
Weight:	46 lbs (21 kg)
Accessories	: Remote Control 2 "AA" Batteries Rod Antenna Owner's Manual

- Designs and specifications are subject to change without notice and without our legal obligation.

CABLE CHANNEL DESIGNATIONS

This model is capable of receiving 125 cable channels. The channels are displayed as 1 ~ 125.

Cable companies often designate the other channels with letters or letter-number combinations. Please check with your local cable company.

The following is a chart of common cable channel designations.

CATV Channel	5A	2	3	4	5	6	7	8	9	10	11	12	13	A	B
TV Display	1	2	3	4	5	6	7	8	9	10	11	12	13	14	15
CATV Channel	C	D	E	F	G	H	I	J	K	L	M	N	O	P	Q
TV Display	16	17	18	19	20	21	22	23	24	25	26	27	28	29	30
CATV Channel	R	S	T	U	V	W	W+1	W+2	W+3	W+4	W+5	W+6	W+7	W+8	W+9
TV Display	31	32	33	34	35	36	37	38	39	40	41	42	43	44	45
CATV Channel	W+10	W+11	W+12	W+13	W+14	W+15	W+16	W+17	W+18	W+19	W+20	W+21	W+22	W+23	W+24
TV Display	46	47	48	49	50	51	52	53	54	55	56	57	58	59	60
CATV Channel	W+25	W+26	W+27	W+28	W+29	W+30	W+31	W+32	W+33	W+34	W+35	W+36	W+37	W+38	W+39
TV Display	61	62	63	64	65	66	67	68	69	70	71	72	73	74	75
CATV Channel	W+40	W+41	W+42	W+43	W+44	W+45	W+46	W+47	W+48	W+49	W+50	W+51	W+52	W+53	W+54
TV Display	76	77	78	79	80	81	82	83	84	85	86	87	88	89	90
CATV Channel	W+55	W+56	W+57	W+58	A-5	A-4	A-3	A-2	A-1	W+59	W+60	W+61	W+62	W+63	W+64
TV Display	91	92	93	94	95	96	97	98	99	100	101	102	103	104	105
CATV Channel	W+65	W+66	W+67	W+68	W+69	W+70	W+71	W+72	W+73	W+74	W+75	W+76	W+77	W+78	W+79
TV Display	106	107	108	109	110	111	112	113	114	115	116	117	118	119	120
CATV Channel	W+80	W+81	W+82	W+83	W+84										
TV Display	121	122	123	124	125										

FUNAI CORPORATION LIMITED WARRANTY

FUNAI CORP. will repair this product, free of charge in the USA in the event of defect in materials or workmanship as follows:

DURATION:

PARTS: FUNAI CORP. will provide parts to replace defective parts without charge for one (1) year from the date of original retail purchase. Two (2) years for Picture Tube. Certain parts are excluded from this warranty.

LABOR: FUNAI CORP. will provide the labor without charge for a period of ninety (90) days from the date of original retail purchase.

LIMITS AND EXCLUSIONS:

This warranty is extended only to the original retail purchaser. A purchase receipt or other proof of original retail purchase will be required together with the product to obtain service under this warranty.

This warranty shall not be extended to any other person or transferee.

This warranty is void and of no effect if any serial numbers on the product are altered, replaced, defaced or missing. This FUNAI CORPORATION Limited warranty does not apply to any the product not purchased and used in the United States.

This warranty only covers failures due to defects in material or workmanship which occur during normal use. It does not cover damage which occurs in shipment, or failures which are caused by repairs, alterations or product not supplied by FUNAI CORP., or damage which results from accident, misuse, abuse, mishandling, misapplication, alteration, faulty installation, improper maintenance, commercial use such as hotel, rental or office use of this product or damage which results from fire, flood, lightning or other acts of God.

THIS WARRANTY DOES NOT COVER PACKING MATERIALS, ANY ACCESSORIES (EXCEPT REMOTE CONTROL), ANY COSMETIC PARTS, COMPLETE ASSEMBLY PARTS, DEMO OR FLOOR MODELS.

FUNAI CORP. AND ITS REPRESENTATIVES OR AGENTS SHALL IN NO EVENT BE LIABLE FOR ANY GENERAL, INDIRECT OR CONSEQUENTIAL DAMAGES ARISING OUT OF OR OCCASIONED BY THE USE OF OR THE INABILITY TO USE THIS PRODUCT. THIS WARRANTY IS MADE IN LIEU OF ALL OTHER WARRANTIES, EXPRESS OR IMPLIED, AND OF ALL OTHER LIABILITIES ON THE PART OF FUNAI, ALL OTHER WARRANTIES INCLUDING THE WARRANTY OF MERCHANTABILITY, AND FITNESS FOR A PARTICULAR PURPOSE, ARE HEREBY DISCLAIMED BY FUNAI AND ITS REPRESENTATIVES IN THE UNITED STATES.

ALL WARRANTY INSPECTIONS AND REPAIRS MUST BE PERFORMED BY FUNAI AUTHORIZED SERVICE CENTER. THIS WARRANTY IS VALID WHEN THE UNIT IS CARRIED-IN TO FUNAI AUTHORIZED SERVICE FACILITY.

WHEN YOU ARE RETURNING THE PRODUCT FOR SERVICE TO THE FACTORY SERVICE CENTER, PLEASE CONTACT THE FUNAI SERVICE DEPARTMENT TO RECEIVE M.R.A. (MERCHANDISE RETURN AUTHORIZATION) NUMBER PRIOR TO SHIPPING. ANY POSTAGE, INSURANCE AND SHIPPING COST, INCURRED IN PRESENTING OR SENDING YOUR FUNAI/SYMPHONIC PRODUCT FOR SERVICE ARE SHIPPER'S RESPONSIBILITY.

CAREFULLY PACK WITH PROPER PACKING MATERIALS, PREFERABLY IN THE ORIGINAL CARTON.

ATTACH WRITTEN DOCUMENTATION DETAILING THE COMPLAINT, TO THE OUTSIDE OR INSIDE OF THE CARTON.

THE PRODUCT MUST BE ACCOMPANIED BY A COPY OF THE ORIGINAL RETAIL PURCHASE RECEIPT. IF NO PROOF OF PURCHASE IS ATTACHED, THE WARRANTY WILL NOT BE HONORED AND REPAIRS COSTS WILL BE CHARGED.

IMPORTANT:

THIS LIMITED WARRANTY GIVES YOU SPECIFIC LEGAL RIGHTS, YOU MAY HAVE OTHER RIGHTS THAT VARY FROM STATE TO STATE. IF, AT ANY TIME DURING THE WARRANTY PERIOD, YOU ARE UNABLE TO OBTAIN SATISFACTION WITH THE REPAIR OF THIS PRODUCT, PLEASE CONTACT FUNAI CORP.

ATTENTION:

FUNAI CORP. RESERVES THE RIGHT TO MODIFY ANY DESIGN OF THIS PRODUCT WITHOUT PRIOR NOTICE.

For information of your nearest FUNAI Authorized Service Center or general service procedure, please call or write to the following:

FUNAI CORPORATION
Factory Service Center
100 North Street; Teterboro, NJ 07608
Tel :800-242-7158
(Eastern Time 9:00 AM - 4:30 PM)