

OWNER'S MANUAL

Symphonic

13" COLOR TV/VCR COMBINATION

VHS

13TVCR MKIVS

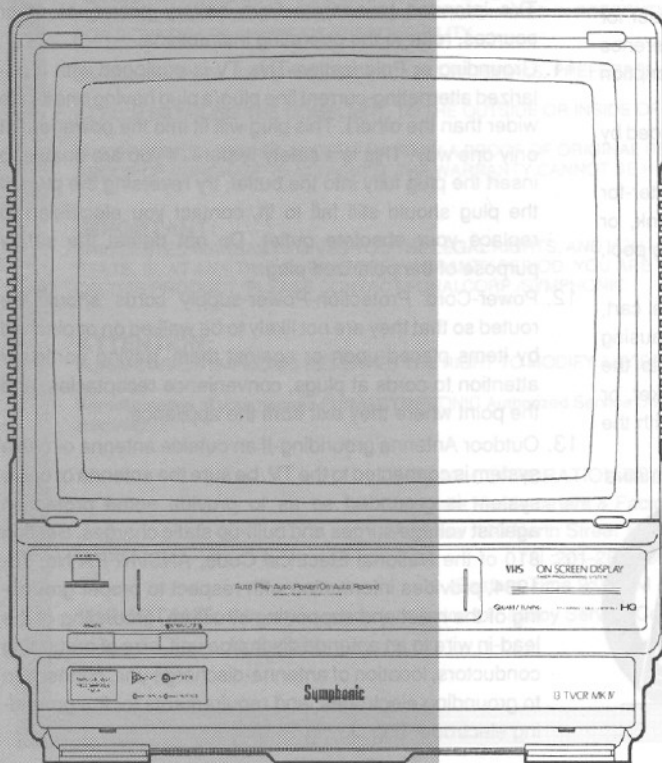

CONTENTS

SAFETY INSTRUCTIONS	2
FEATURES	4
PRECAUTIONS	5
OPERATING CONTROLS AND FUNCTIONS	6
REMOTE CONTROL OPERATION	8
HOW TO USE REMOTE CONTROL	8
INSTALLING THE BATTERIES	9
ANTENNA CONNECTIONS	10
VHF/UHF RECEPTION AREA USING SEPARATE ANTENNAS	10
VHF/UHF COMBINED ANTENNA	11
CABLE AND PAY TV	11
PREPARATION FOR USE	12
CHANNEL MEMORY PROGRAMMING	12
VIDEO CASSETTE	14
SETTING THE CLOCK FOR CORRECT TIME	15
OPERATION	17
T.V. OPERATION	17
VIEWING AND RECORDING THE SAME PROGRAM	18
AUTOMATIC TIMER RECORDING	20
SETTING THE SLEEP TIMER	24
ONE TOUCH RECORDING	25
PLAYBACK	26
FRONT SCREEN COVER REMOVAL	28
REMOVING STEPS	28
REINSTALLATION STEPS	28
TROUBLESHOOTING GUIDE	29
MAINTENANCE	29
SPECIFICATIONS	30
WARRANTY	31

Please read before
using this equipment

WARNING:

TO REDUCE THE RISK OF FIRE OR ELECTRIC SHOCK, DO NOT EXPOSE THIS APPLIANCE TO RAIN OR MOISTURE.

**CAUTION**

**RISK OF ELECTRIC SHOCK
DO NOT OPEN**



CAUTION: TO REDUCE THE RISK OF ELECTRIC SHOCK, DO NOT REMOVE COVER (OR BACK) NO USER SERVICEABLE PARTS INSIDE. REFER SERVICING TO QUALIFIED SERVICE PERSONNEL.



THIS SYMBOL INDICATES THAT DANGEROUS VOLTAGE CONSTITUTING A RISK OF ELECTRIC SHOCK IS PRESENT WITHIN THIS UNIT.



THIS SYMBOL INDICATES THAT THERE ARE IMPORTANT OPERATING AND MAINTENANCE INSTRUCTIONS IN THE LITERATURE ACCOMPANYING THE APPLIANCE.

"IMPORTANT SAFEGUARDS"

1. Read instructions-All the safety and operating instructions should be read before the appliance is operated.
2. Retain Instructions-The safety and operating instructions should be retained for future reference.
3. Heed Warnings-All warnings on the appliance and in the operating instructions should be adhered to.
4. Follow Instructions-All operating and use instructions should be followed.
5. Cleaning-Unplug TV from the wall outlet before cleaning. Do not use liquid cleaners or aerosol cleaners. Use a damp cloth for cleaning.

EXCEPTION : A product that is meant for uninterrupted service and that for some specific reason, such as the possibility of the loss of an authorization code for a CATV converter, is not intended to be unplugged by the user for cleaning or any other purpose, may exclude the reference to unplugging the appliance in the cleaning description otherwise required in item 5.
6. Attachments-Do not use attachments not recommended by the TV manufacturer as they may cause hazards.
7. Water and Moisture-Do not use this TV near water-for example, near a bath tub, wash bowl, kitchen sink, or laundry tub, in a wet basement, or near a swimming pool, and the like.
8. Accessories-Do not place this TV on an unstable cart, stand, tripod, bracket, or table. The TV may fall, causing serious injury to someone, and serious damage to the appliance. Use only with a cart, stand, tripod, bracket, or table recommended by the manufacturer, or sold with the TV. Any mounting of the appliance should follow the manufacturer's instructions and should use a mounting accessory recommended by the manufacturer. An appliance and cart combination should be moved with care. Quick stops, excessive force, and uneven surfaces may cause the appliance and cart combination to overturn.

PORTABLE CART WARNING



S3126A
9. Ventilation-Slots and openings in the cabinet and the back or bottom are provided for ventilation and to ensure reliable operation of the TV and to protect it from overheating, these openings must not be blocked or covered. The openings should never be blocked by placing the TV on a bed, sofa, rug, or other similar surface. This TV should never be placed near or over a radiator or heat register. This TV should not be placed in a built-in installation such as a bookcase or rack unless proper ventilation is provided or the manufacturer's instructions have been adhered to .
10. Power Sources-This TV should be operated only from the type of power source indicated on the marking label. If you are not sure of the type of power supply to your home, consult your appliance dealer or local power company. For TVs intended to operate from battery power, or other sources, refer to the operating instructions.
11. Grounding or Polarization-This TV is equipped with a polarized alternating-current line plug(a plug having one blade wider than the other). This plug will fit into the power outlet only one way. This is a safety feature. If you are unable to insert the plug fully into the outlet, try reversing the plug. If the plug should still fail to fit, contact you electrician to replace your obsolete outlet. Do not defeat the safety purpose of the polarized plug.
12. Power-Cord Protection-Power-supply cords should be routed so that they are not likely to be walked on or pinched by items placed upon or against them, paying particular attention to cords at plugs, convenience receptacles, and the point where they exit from the appliance.
13. Outdoor Antenna grounding-If an outside antenna or cable system is connected to the TV, be sure the antenna or cable system is grounded so as to provide some protection against voltage surges and built-up static charges. Section 810 of the National Electrical Code, ANSI/NFPA No. 70-1984, provides information with respect to proper grounding of the mast and supporting structure, grounding of the lead-in wire to an antenna discharge unit, size of grounding conductors, location of antenna-discharge unit, connection to grounding electrodes, and requirements for the grounding electrode. (Fig. A)

FIGURE A

EXAMPLE OF ANTENNA GROUNDING AS PER NATIONAL ELECTRICAL CODE

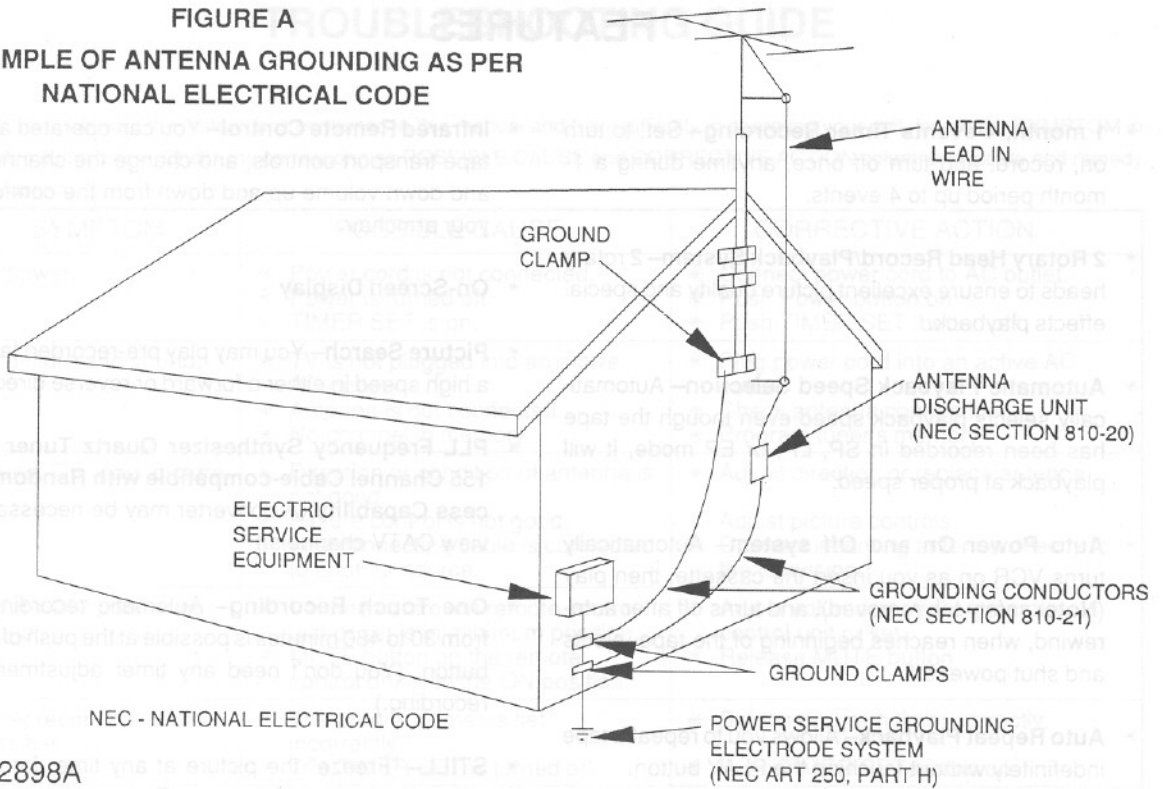

S2898A

14. Lightning-For added protection for this TV receiver during a lightning storm, or when it is left unattended and unused for long periods of time, unplug it from the wall outlet and disconnect the antenna or cable system. This will prevent damage to the TV due to lightning and power-line surges.
 15. Power Lines-An outside antenna system should not be located in the vicinity of overhead power lines or other electric light or power circuits, or where it can fall into such power lines or circuits. When installing an outside antenna system, extreme care should be taken to keep from touching such power lines or circuits as contact with them might be fatal.
 16. Overloading-Do not overload wall outlets and extension cords as this can result in a risk of fire or electric shock.
 17. Object and Liquid Entry-Never push objects of any kind into this TV through opening as they may touch dangerous voltage points or shortout parts that could result in a fire or electric shock. Never spill liquid of any kind on the TV.
 18. Servicing-Do not attempt to service this TV yourself as opening or removing covers may expose you to dangerous voltage or other hazards. Refer all servicing to qualified service personnel.
 19. Damage Requiring Service-Unplug this TV from the wall
- ered by the operating instructions as improper adjustment of other controls may result in damage and will often require extensive work by a qualified technician to restore the TV to its normal operation.
- e. If the TV has been dropped or the cabinet has been damaged.
 - f. When the TV exhibits a distinct change in performance-this indicates a need for service.
20. Replacement Parts-When replacement parts are required, be sure the service technician had used replacement parts specified by the manufacturer that have the same characteristics as the original part. Unauthorized substitutions may result in fire, electric shock, injury to persons or other hazards.
 21. Safety Check-Upon completion of any service or repairs to this TV, ask the service technician to perform routine safety checks to determine that the TV is in proper operating condition.

FEATURES

- * **1 month, 4-events Timer Recording**— Set, to turn on, record, and turn off once, anytime during a 1-month period up to 4 events.
- * **2 Rotary Head Record/Playback System**— 2 rotary heads to ensure excellent picture quality and special effects playback.
- * **Automatic Playback Speed Selection**— Automatically selects playback speed even though the tape has been recorded in SP, LP, or EP mode, it will playback at proper speed.
- * **Auto Power On and Off system**— Automatically turns VCR on as you insert the cassette, then play (**Note:** safety tab removed), and turns off after auto-rewind, when reaches beginning of the tape, ejects and shut power off.
- * **Auto Repeat Playback**— Allows you to repeat a tape indefinitely without touching the PLAY button.
- * **DEW Sensor System with Dew Indicator**
- * **Infrared Remote Control**— You can operated all the tape transport controls, and change the channel up and down volume up and down from the comfort of your armchair.
- * **On-Screen Display**
- * **Picture Search**— You may play pre-recorded tape at a high speed in either a forward or reverse direction.
- * **PLL Frequency Synthesizer Quartz Tuner with 155 Channel Cable-compatible with Random Access Capability** (A converter may be necessary to view CATV channels.)
- * **One Touch Recording**— Automatic recording for from 30 to 480 minutes is possible at the push of OTR button. (You don't need any timer adjustment for recording.)
- * **STILL**— "Freeze" the picture at any time, for close viewing of a particular scene. Recorded tape in EP mode shows better clear picture.
- * **Three Tape Speeds for Record/Playback**— Select SP mode (Standard short play), LP mode (Long play) and EP mode (Extended play) for up to eight hours of recording/playback with a T-160 tape. For best results, we recommend T-60 or T-120 tapes.

PRECAUTIONS

SUPPLIED ACCESSORIES

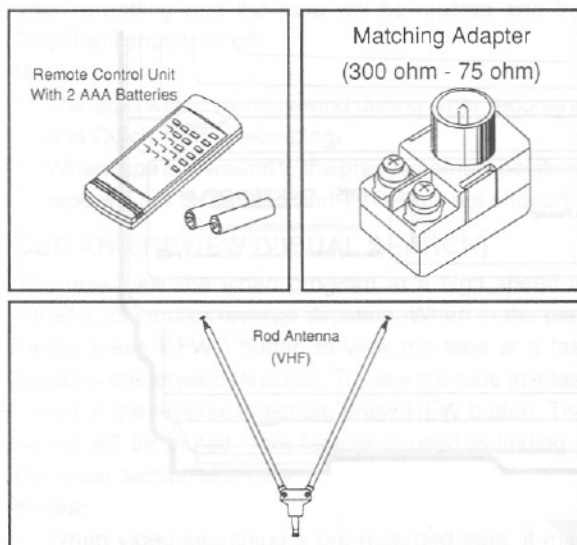

LOCATION

For safe operation and satisfactory performance of your unit, keep the following in mind when selecting a place for its installation:

- * Shield it from direct sunlight and keep it away from sources of intense heat.
- * Avoid dusty or humid places.
- * Avoid places with insufficient ventilation for proper heat dissipation. Do not block the ventilation holes at the top and bottom of the unit. Do not place the unit on a carpet because this will block the ventilation holes.
- * Install unit in a horizontal position.
- * Avoid locations subject to strong vibration.
- * Do not place the unit near strong magnetic fields.
- * Do not move the unit from a cold to a hot place or vice versa.

AVOID THE HAZARDS OF ELECTRICAL SHOCK AND FIRE

- * Do not handle the power cord with wet hands.
- * Do not pull on the power cord when disconnecting it from an AC wall outlet. Grasp it by the plug.
- * If, by accident, water is spilled on your unit, unplug the power cord immediately and take the unit to an authorized video service center for servicing.
- * Do not put your fingers or objects into the VCR cassette holder.
- * Do not place anything directly on top of the unit.

DEW WARNING/INDICATOR

This video cassette recorder is equipped with a sensor which prevents DEW condensation. If excessive moisture is present inside the unit, the [d] letter on the digital display goes on. While the indicator is lit, safety device prevents the unit from operating until moisture is gone. Moisture condensation may occur inside the unit when it is removed from a cold place to a warm place, or after heating a cold room or under conditions of high humidity. Therefore when the [d] letter light is on turn the POWER button off and allow at least 2 hours for the unit to dry out.

Note: DEW indicator may not go on for first 15 minutes even if moisture condensation may occur inside the unit when room temperature or humidity changes suddenly. In this case, do not insert the cassette for first 30 minutes.

IMPORTANT COPYRIGHT INFORMATION

Unauthorized recording or use of broadcast television programming, video tape, film, or other copyrighted material may violate applicable copyright laws. We assume no responsibility for the unauthorized duplication, use or other acts which infringe upon the rights of copyright owners.

OPERATING CONTROLS AND FUNCTIONS

— FRONT VIEW —

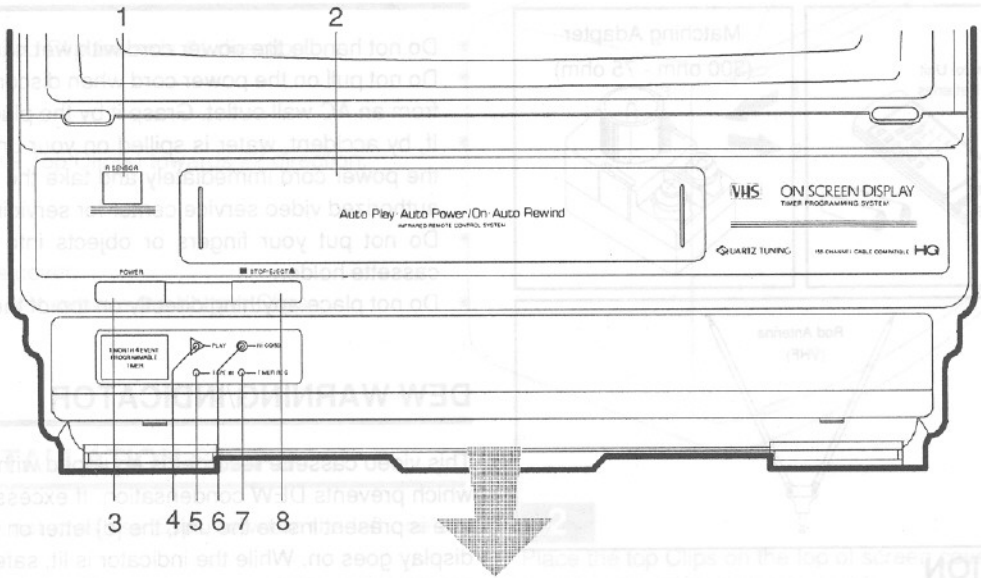

— REAR VIEW —

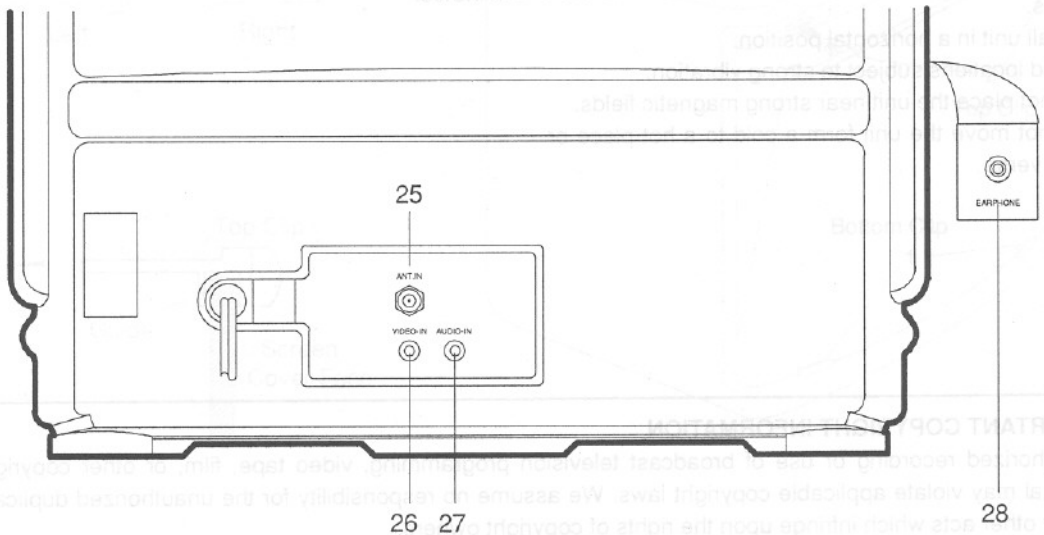

- 1 **REMOTE SENSOR**– Receives the infrared control signals from the handheld remote control unit.
- 2 **CASSETTE COMPARTMENT**
- 3 **POWER button**– To turn the unit on and off.
- 4 **PLAY indicator**– lights when in the Play mode.
- 5 **TAPE IN indicator**– lights when the cassette tape is inserted.
- 6 **RECORD indicator**– lights when in the Recording mode.
- 7 **TIMER REC indicator**– lights when in the Timer Recording mode.
- 8 **STOP/EJECT button**– To stop tape motion and remove the tape from VCR.
- 9 **REW button**– To rewind tape, or to view video, in reverse, during play mode at a faster than normal speed. Press play button to return VCR to normal playback speed.
- 10 **F.FWD button**– To advance tape faster than normal or to view video, in forward direction, during play mode at a faster than normal speed. Press play button to return VCR to normal playback speed.
- 11 **PLAY button**– To begin playback of a tape.
- 12 **PAUSE button**– To temporarily stop tape during playback or manual recording.
- 13 **REC/OTR button**– allows you to record continuously or to begin One Touch Recording by pressing twice as many times as needed.

- 14 **CHANNEL UP/DOWN button**– To select the channel for viewing or recording.
- 15 **VOLUME UP/DOWN button**– To adjust the volume level.
- 16 **MONITOR button**– To turn the monitor screen on and off when in the recording mode.
- 17 **TAPE SPEED button**– To set desired recording speed. (SP/LP/EP)
- 18 **BAND selector switch** – To select TV or CATV(STD/HRC) mode.
- 19 **AUTO REPEAT switch**– To select auto repeat playback mode.
- 20 **TRACKING control**– Adjust to minimize video "noise" (lines or dots on screen) during playback.
- 21 **BRIGHTNESS control**– See page 17 for detail.
- 22 **CONTRAST control**– See page 17 for detail.
- 23 **COLOR control**– See page 17 for detail.
- 24 **TINT control**– See page 17 for detail.
- 25 **ANT.IN jack**– Connect 75-ohm antenna.
- 26 **VIDEO INPUT jack**– Connect to video output jack of your video camera or another VCR.
- 27 **AUDIO INPUT jack**– Connect to audio output jack of a video camera or another VCR.
- 28 **EARPHONE jack**– To connect earphones (not supplied) for personal listening.

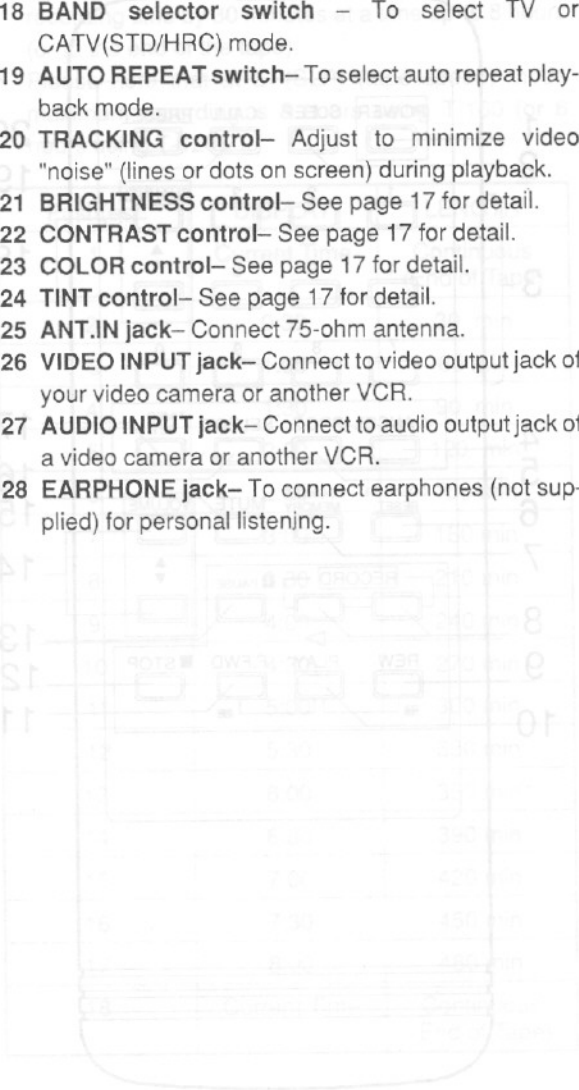

REMOTE CONTROL OPERATION

HOW TO USE REMOTE CONTROL

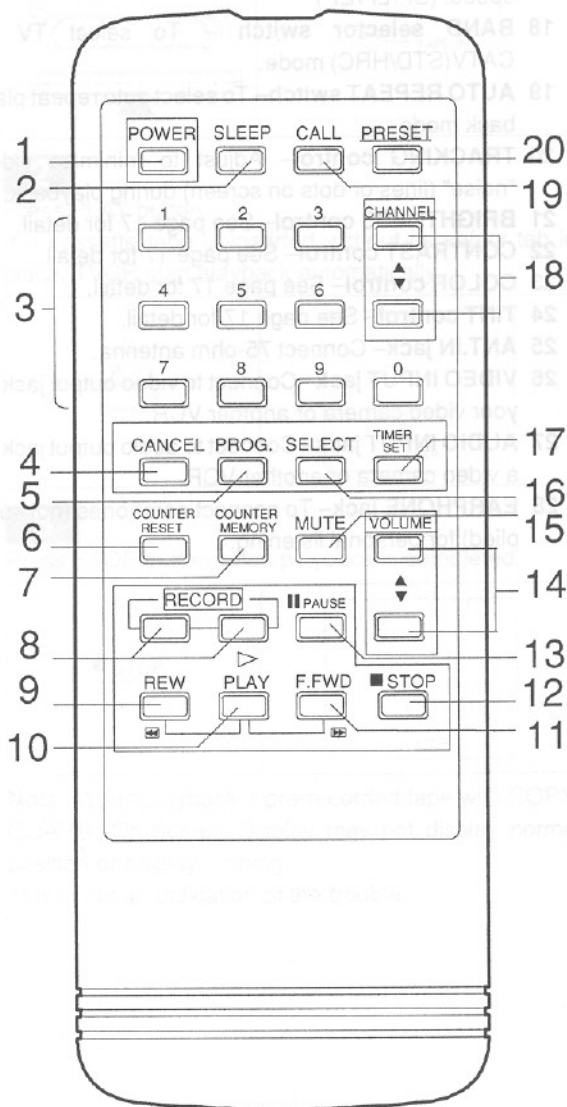

- 1. POWER button**— To turn power on and off.
- 2. SLEEP button**— To activate the sleep function.
- 3. NUMERICAL KEYS**— To select desired channels. They cannot be used to set desired channel during Timer Recording. If you want to select channel among 1 to 9, first 0 Key and then push desired Key among 1 to 9.
- 4. CANCEL button**— To cancel memorized Timer Program.
- 5. PROG. button**— To set Timer Recording Program and the current time.
- 6. COUNTER RESET button** — To reset counter to 0000.
- 7. COUNTER MEMORY button** — To set counter memory-in.
- 8. RECORD buttons (OTR buttons)**— To begin recording, push both 2 buttons (1 is a safety button) together, allows you to record continuously or to begin One Touch Recording by pressing twice as many times as needed.
- 9. REW button**— To rewind tape, or to view video in reverse during play mode at a faster than normal speed. Press PLAY button to return normal playback speed.
- 10. PLAY button**— To playback the tape.
- 11. F.FWD button**— To advance tape faster than normal or to view video in forward direction during play mode at a faster than normal speed. Press PLAY button to return normal playback speed.
- 12. STOP button**— To stop the tape.
- 13. PAUSE button**— To stop the tape temporarily during playback or recording. To view a still picture during playback.
- 14. VOLUME buttons**—To adjust desired volume level by pressing either "▲" or "▼" button.
- 15. MUTE button** — To mute sound. Press again to resume sound.
- 16. SELECT button** — To select setting mode.
- 17. TIMER SET button** — To activate the automatic recording timer.
- 18. CHANNEL buttons**— To select desired channel by pressing either "▲" or "▼" button. They cannot be used during Timer Recording.
- 19. CALL button**— To call channel display, counter number, and the current time on the screen.
- 20. PRESET button** — To select the channel memory mode.

INSTALLING THE BATTERIES

1

Slide the battery compartment cover on the remote unit in the direction of the arrow.

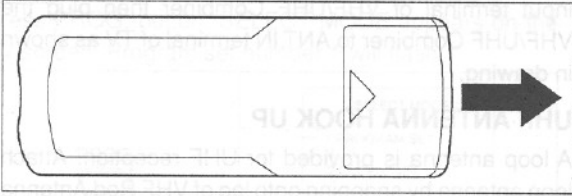

2

Insert 2 "AAA" penlight batteries into the battery compartment in the direction as indicated by the polarity (+/-) markings.

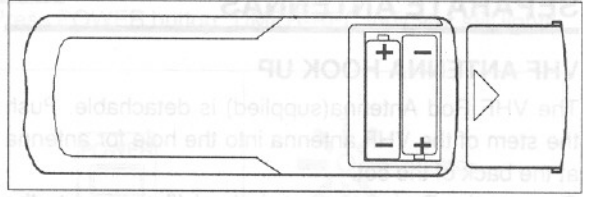

3

Replace the cover

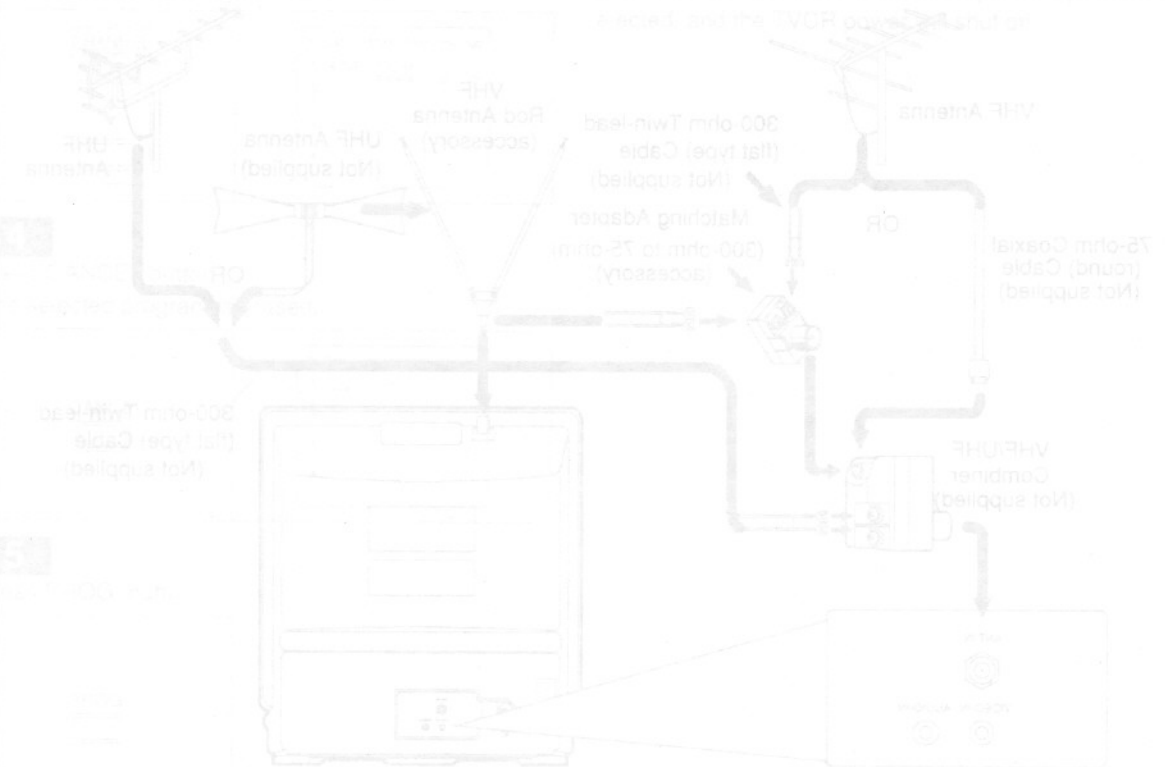
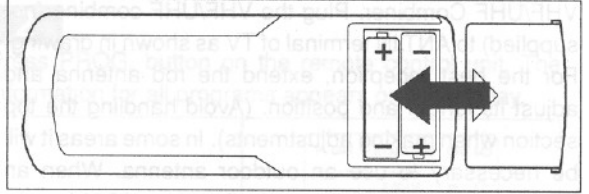

ANTENNA CONNECTIONS

VHF/UHF RECEPTION AREA USING SEPARATE ANTENNAS

VHF ANTENNA HOOK UP

The VHF Rod Antenna (supplied) is detachable. Push the stem of the VHF antenna into the hole for antenna at the back of the set.

Connect the Rod antenna twin lead (flat) wires to the 300/75 ohm matching transformer (supplied). Plug the Matching Transformer to the VHF input terminal of VHF/UHF Combiner. Plug the VHF/UHF combiner (not supplied) to ANT.IN terminal of TV as shown in drawing. For the best reception, extend the rod antenna and adjust its length and position. (Avoid handling the top section when making adjustments). In some areas it will be necessary to use an outdoor antenna. When an outdoor VHF antenna is used, disconnect the detachable Rod antenna twin lead, and connect the lead-in wires from an outdoor antenna to the terminals of the 300/75 ohm matching transformer as shown in drawing.

If you already have a round type 75 ohm coaxial cable coming from your outdoor antenna, connect to the VHF input terminal of VHF/UHF Combiner then plug the VHF/UHF Combiner to ANT.IN terminal of TV as shown in drawing.

UHF ANTENNA HOOK UP

A loop antenna is provided for UHF reception. Attach loop antenna by snapping onto leg of VHF Rod Antenna and connect the ends of this loop antenna to the VHF/UHF Combiner as shown in drawing.

Plug the VHF/UHF Combiner to ANT.IN terminal of TV as shown drawing.

The loop antenna can be adjusted in any direction or angle to get the best UHF reception.

NOTE: If it is difficult to get good reception with the indoor antenna, using an outdoor antenna is recommended. Before an outdoor antenna is connected to the set, the indoor antenna should be disconnected.

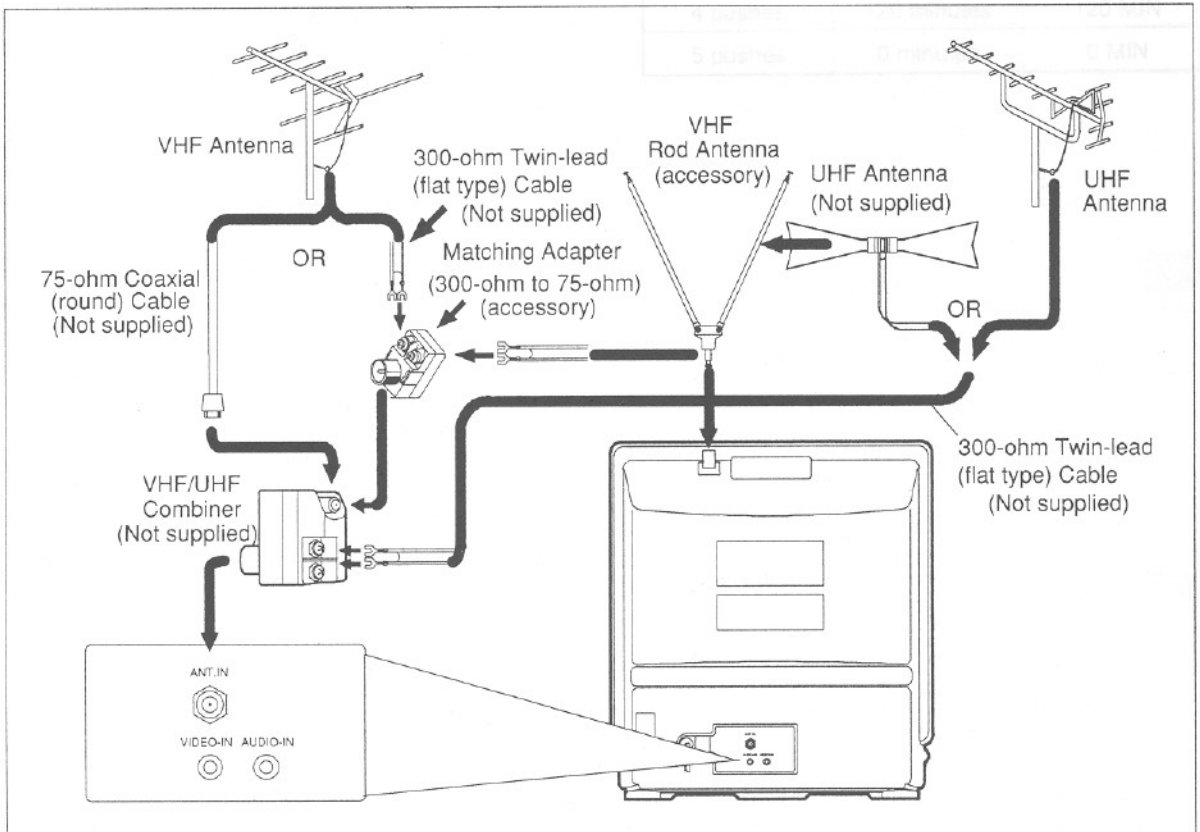

VHF/UHF COMBINED ANTENNA

A VHF/UHF 75 ohm combination antenna can be connected to ANT.IN terminal.

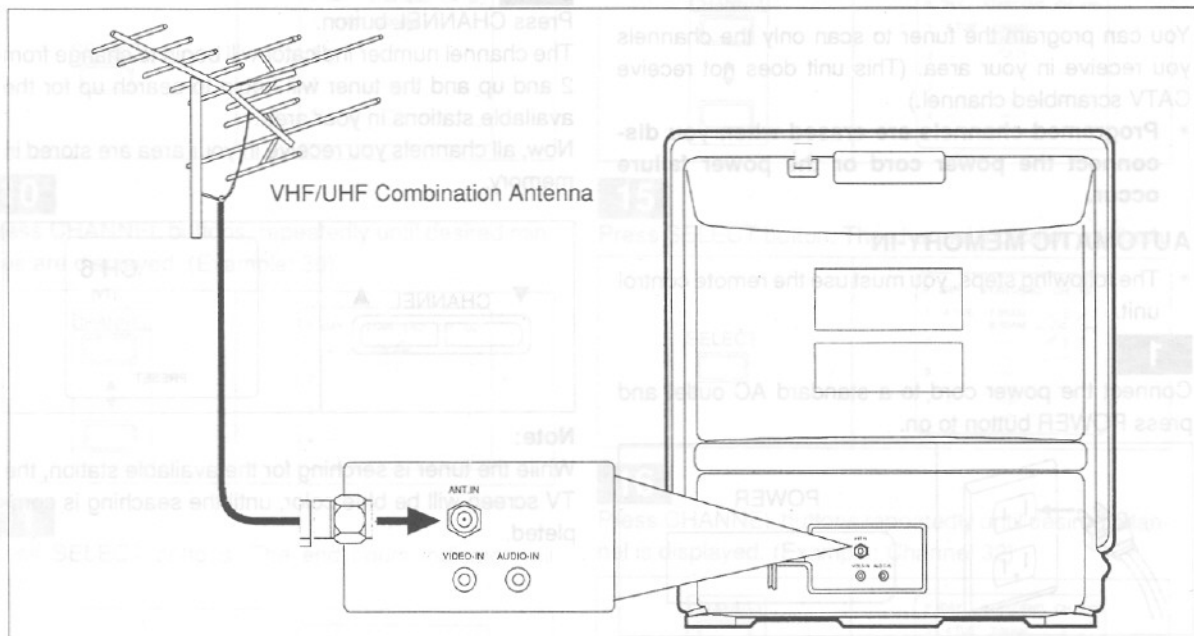

CABLE AND PAY TV

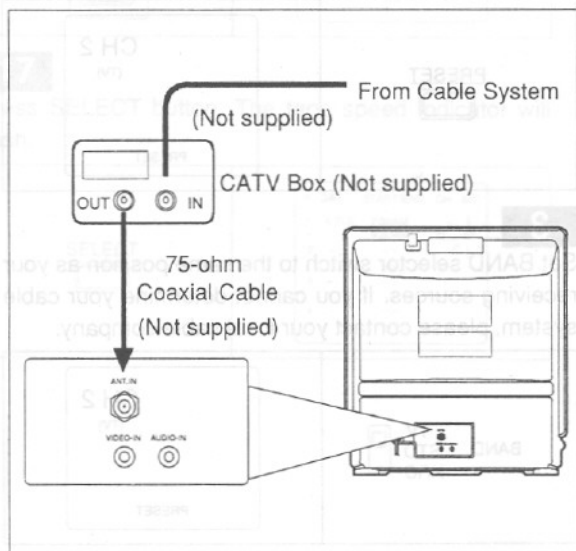
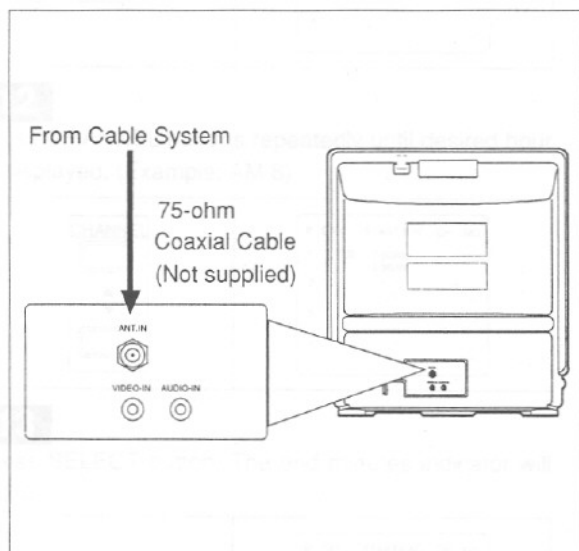

Note to CATV (Cable TV) system installer:

This reminder is provided to call the CATV (Cable TV) system installer's attention to Article 820-22 of the NEC that provides guidelines for proper grounding and, in particular, specifies that the cable ground shall be connected to the grounding system of the building, as close to the point of cable entry as possible.

PREPARATION FOR USE

CHANNEL MEMORY PROGRAMMING

You can program the tuner to scan only the channels you receive in your area. (This unit does not receive CATV scrambled channel.)

* **Programed channels are erased when you disconnect the power cord or the power failure occur.**

AUTOMATIC MEMORY-IN

* The following steps, you must use the remote control unit.

1

Connect the power cord to a standard AC outlet and press POWER button to on.

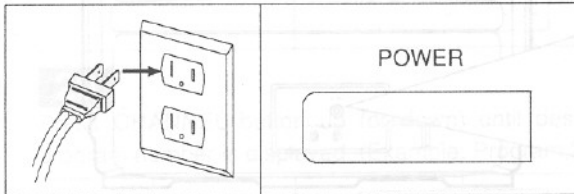

2

Press PRESET button on the remote control unit.

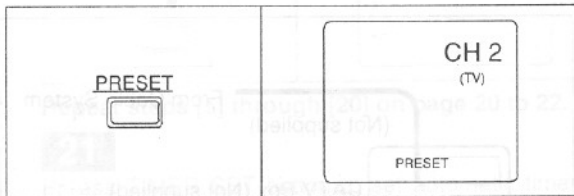

3

Set BAND selector switch to the same position as your receiving sources. If you cannot determine your cable system, please contact your local cable company.

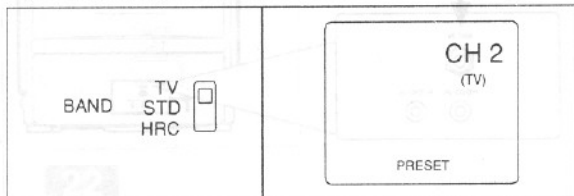

4

Press CHANNEL button.

The channel number indicator will begin to change from 2 and up and the tuner will begin to search up for the available stations in your area.

Now, all channels you receive in your area are stored in memory.

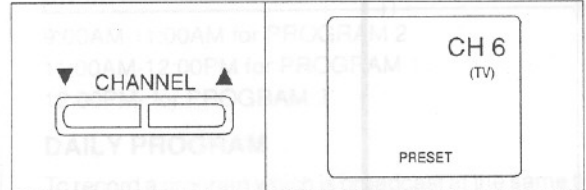

Note:

While the tuner is searching for the available station, the TV screen will be blue color, until the searching is completed.

To ERASE PRESET CHANNELS

1

Press PRESET button on the remote control unit.

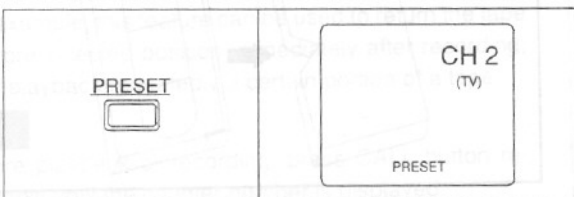

Note:

While in preset mode, the TV screen will be in blue color.

2

Select the channel number you want to erase with 10 keys.

(Example: Channel 32)

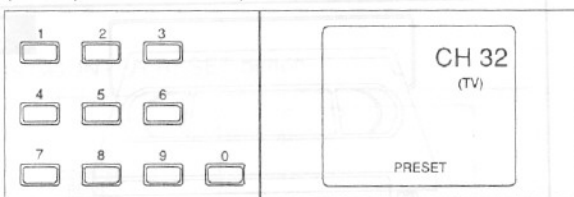

3

Press CANCEL button on the remote control unit. Channel indicator will flash.

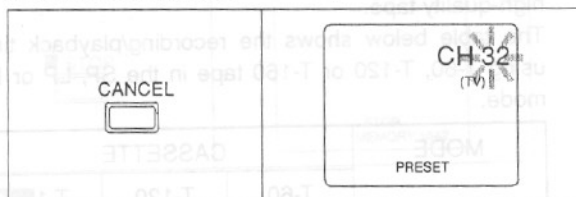

4

Press PRESET button, the channel indicator will stop flashing. (TV screen will be blue or may show the station you are going to erase). Press channel UP or DOWN button to erase the channel number. Now, channel 32 is erased.

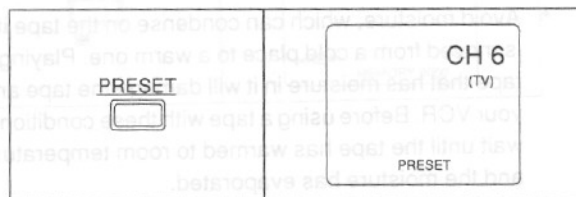

Repeat steps [1] to [4] for each program you want to erase.

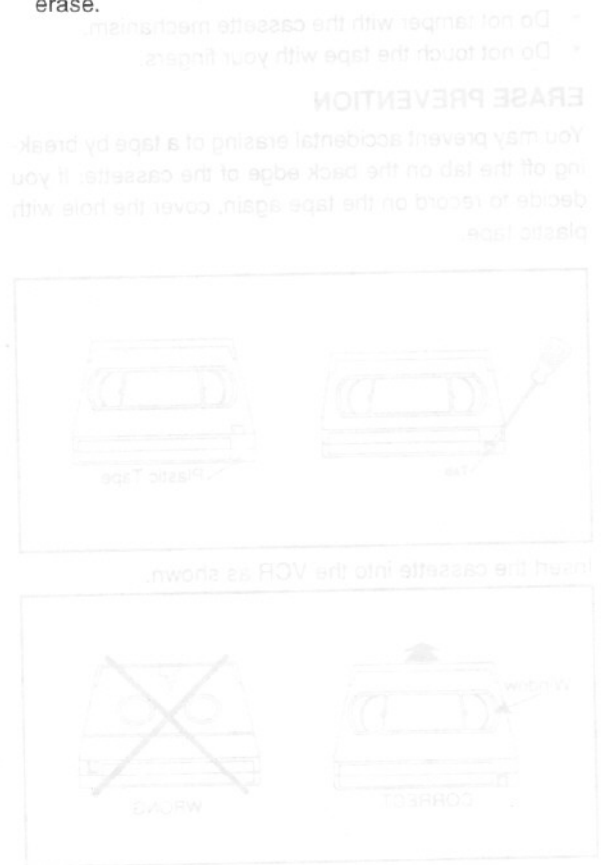

VIDEO CASSETTE

This VCR will operate with any cassette that has the VHS mark. For best results we recommend the use of high-quality tape.

The table below shows the recording/playback time using T-60, T-120 or T-160 tape in the SP, LP or EP mode.

MODE	CASSETTE		
	T-60	T-120	T-160
SP Mode	1 hour	2 hours	2-2/3 hours
LP Mode	2 hours	4 hours	5-1/3 hours
EP(SLP) Mode	3 hours	6 hours	8 hours

When handling video tapes, take the following precautions

- * Avoid moisture, which can condense on the tape if it is moved from a cold place to a warm one. Playing a tape that has moisture in it will damage the tape and your VCR. Before using a tape with these conditions, wait until the tape has warmed to room temperature and the moisture has evaporated.
- * Avoid extreme heat, high humidity and magnetic fields.
- * Do not tamper with the cassette mechanism.
- * Do not touch the tape with your fingers.

ERASE PREVENTION

You may prevent accidental erasing of a tape by breaking off the tab on the back edge of the cassette. If you decide to record on the tape again, cover the hole with plastic tape.

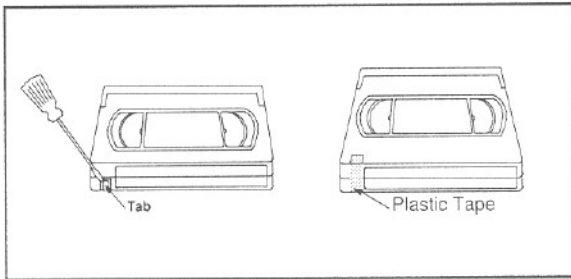

Insert the cassette into the VCR as shown.

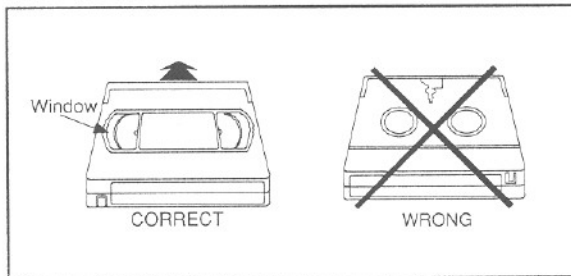

Store the cassette in its case as shown.

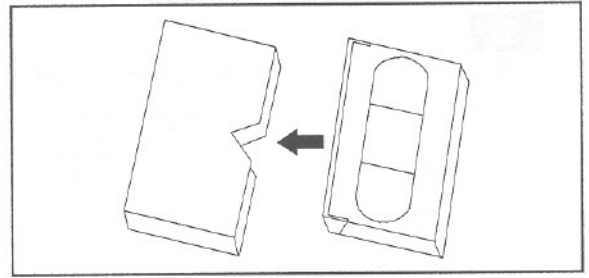

INSERTING A CASSETTE

Insert the cassette in the direction as shown. Push in gently, but continuously, on the center-back of the cassette until it is drawn completely into the VCR.

VCR is automatically turned on, and cassette-in indicator will light when the cassette is properly inserted.

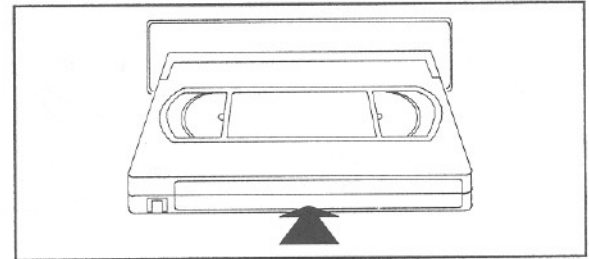

REMOVING A CASSETTE

1

Press EJECT button.

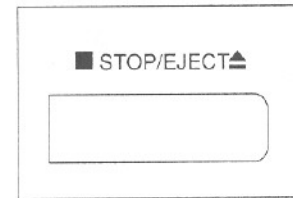

2

When the cassette-in indicator goes off and the cassette stops moving, pull the cassette out of the cassette compartment and store it properly.

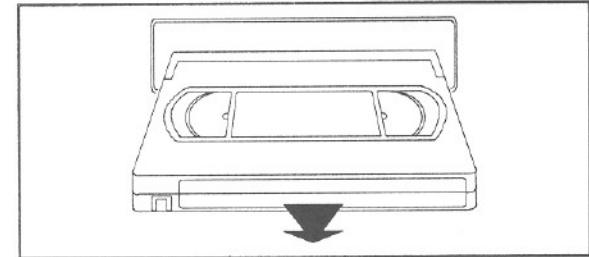

SETTING THE CLOCK FOR CORRECT TIME

* The following steps, you must use the remote control unit.

In the example below, the clock is to be set to Monday at 5:40PM.

1

Make sure the POWER is ON.

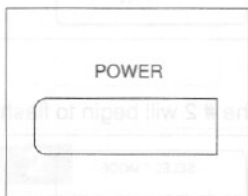

2

Press PROG. button. "CLOCK SET MODE" appears on the TV screen, and the month indicator will flash.

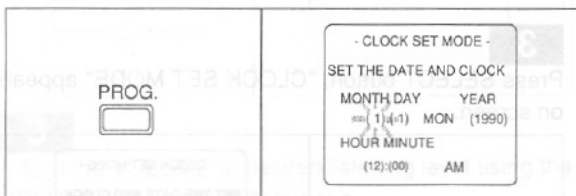

3

Press CHANNEL button, up (or down) repeatedly until the desired month is displayed. (Example: 6)

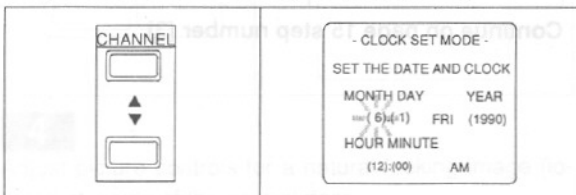

4

Press SELECT button. The day indicator will flash.

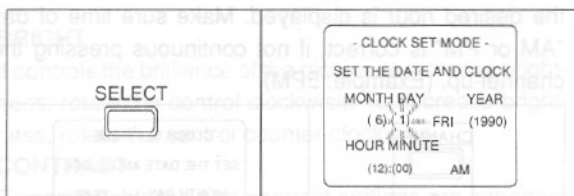

5

Press CHANNEL button, up (or down) repeatedly until the desired day is displayed. (Example: 3)

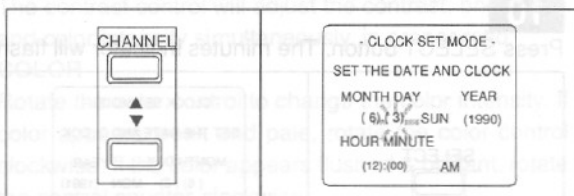

6

Press SELECT button. The year indicator will flash.

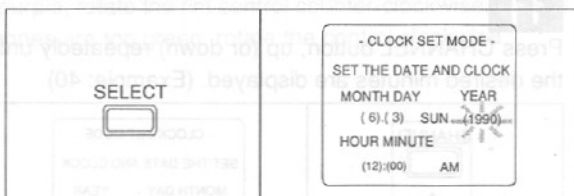

7

Press CHANNEL button, up (or down) repeatedly until the desired year is displayed. (Example: 1991)

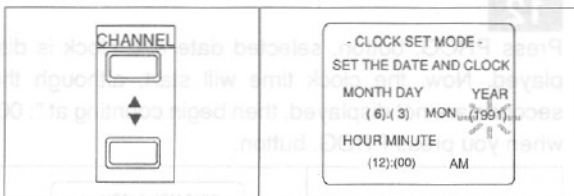

Date of week will be set automatically.

8

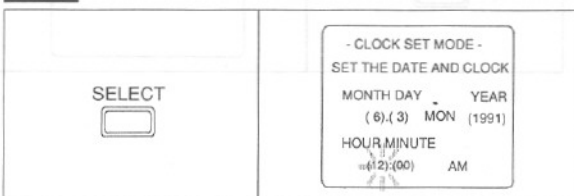

Press SELECT button. The hours indicator will flash.

9

Press CHANNEL button, up (or down) repeatedly until the desired hour is displayed. Make sure time of day "AM or PM" is correct, if not continuous pressing the channel-up. (Example: 5PM)

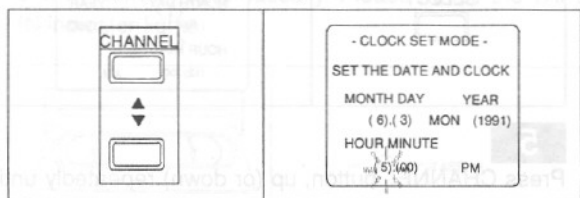
**10**

Press SELECT button. The minutes indicator will flash.

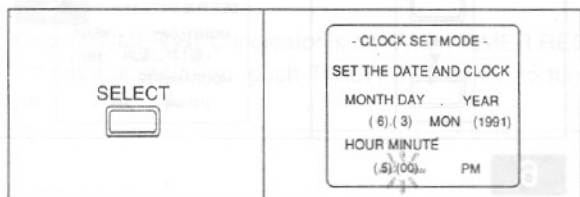
**11**

Press CHANNEL button, up (or down) repeatedly until the desired minutes are displayed. (Example: 40)

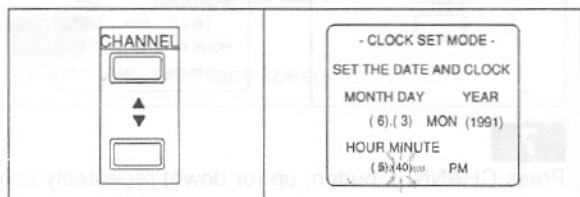
**12**

Press PROG. button, selected date and clock is displayed. Now, the clock time will start, although the seconds are not displayed, then begin counting at ": 00" when you press PROG. button.

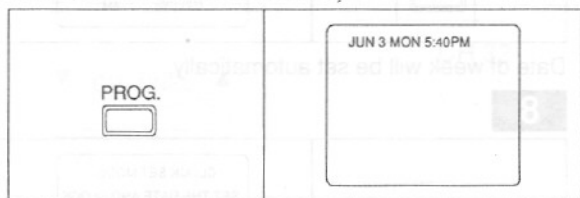
**CHANGING DATE OR CLOCK****1**

Press PROG. button, SELECT mode appear on the screen and number "1" is flashing.

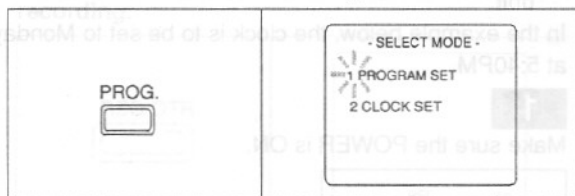
**2**

Press the number # 2 button, the # 2 will begin to flash.

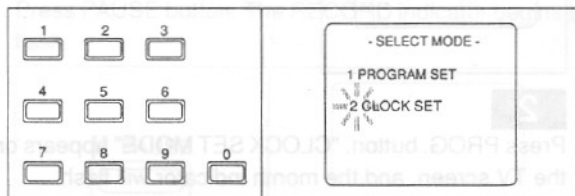
**3**

Press SELECT button, "CLOCK SET MODE" appears on screen.

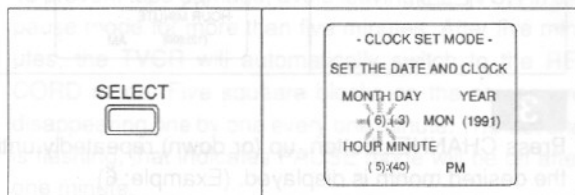

Continue on page 15 step number [3].

OPERATION

T.V. OPERATION

1

Push POWER button to ON.

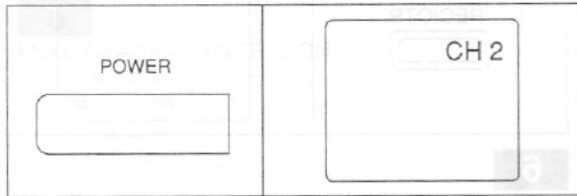

2

Select the desired channel.

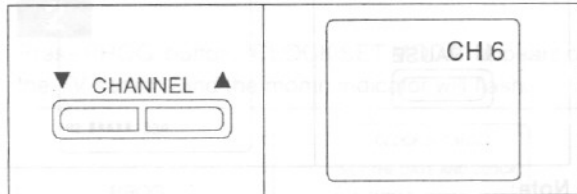

3

Adjust the VOLUME to desired listening level using the VOLUME UP and DOWN buttons

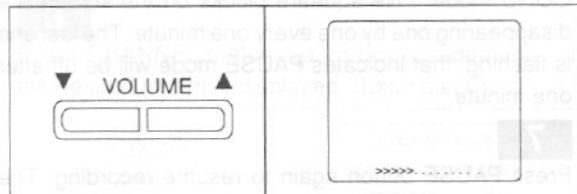

4

Adjust picture controls for a natural looking image (located at inside of the control door).

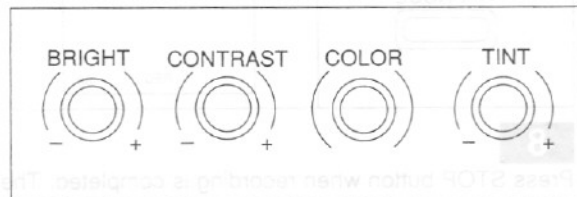

BRIGHT

It controls the brilliance of the picture, to increase brightness, rotate the control clockwise. To decrease brightness, rotate the control counter-clockwise.

CONTRAST

Correct brightness and contrast settings are important to obtain a natural image. To increase the contrast, rotate the control clockwise. To decrease contrast, rotate the control counter-clockwise.

The contrast control will adjust the contrast, brightness and color intensity simultaneously, in proper ratio.

COLOR

Rotate the color control to change the color intensity. If color appears weak and pale, rotate the color control clockwise. If the color appears flushed & brilliant, rotate the control counter-clockwise.

TINT (HUE)

Adjust the tint control as follows: If facial tones are too purple, rotate the tint control counter-clockwise. If facial tones are too green, rotate the control clockwise.

VIEWING AND RECORDING THE SAME PROGRAM

1

Insert a cassette with erasure prevention tab intact. The unit will turn on automatically. Please notice the TAPE IN indicator lights.

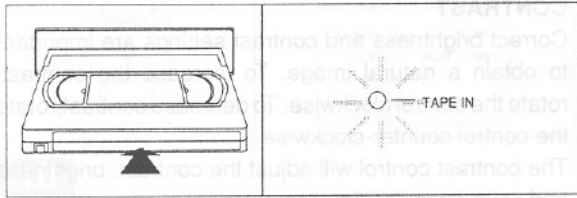

2

Ensure TIMER REC indicator is off. When TIMER REC indicator is set to on, push TIMER SET button to turn off.

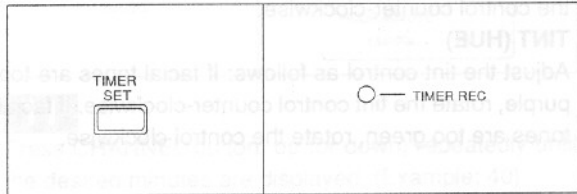

3

Select the desired tape speed. (SP/LP/EP)

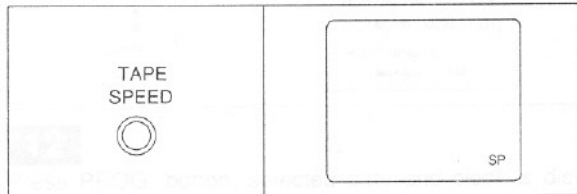

4

Select the channel to be recorded.

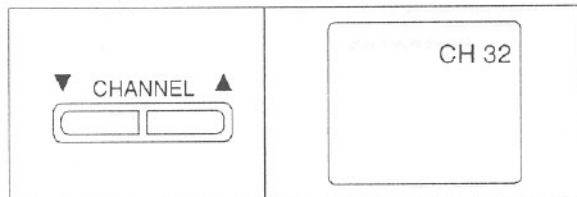

5

Press RECORD button. The RECORD indicator will light.

If you want to edit out some material while you are recording.

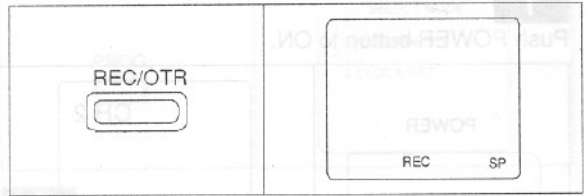

6

Press PAUSE button. The RECORD indicator begins to flash.

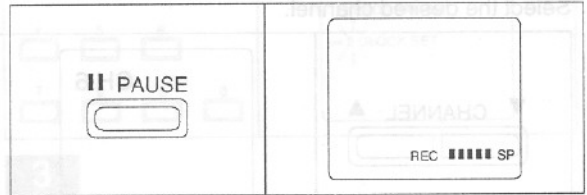

Note:

To prevent tape damage, avoid leaving the TVCR in the pause mode for more than five minutes. After five minutes, the TVCR will automatically switch to the RECORD mode. Five square blocks on the screen are disappearing one by one every one minute. The last one is flashing, that indicates PAUSE mode will be off after one minute.

7

Press PAUSE button again to resume recording. The RECORD indicator stops flashing.

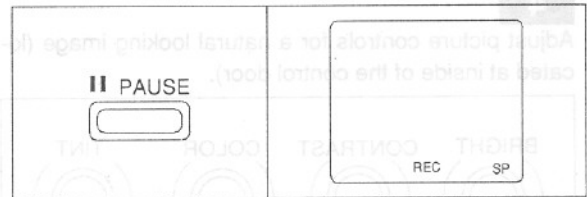

8

Press STOP button when recording is completed. The RECORD indicator will go off.

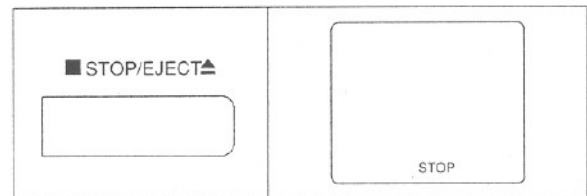

COUNTER MEMORY BUTTON

The MEMORY button can be used during rewind and F.FWD mode to stop tape as tape rewinds to counter display of approx. 0000.

For example, this feature can be used to return the tape to a pre-selected position immediately after recording, or to playback repeatedly a certain portion of a tape.

1

Before playback or recording, press CALL button repeatedly until the counter number is displayed.

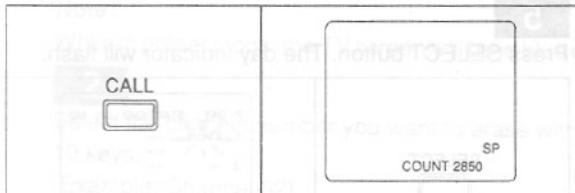

2

Press COUNTER RESET button.

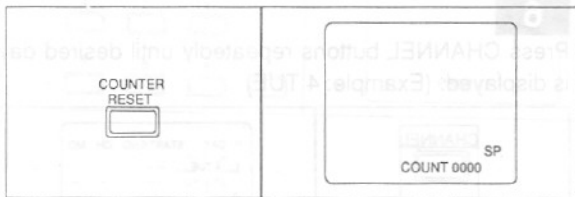

3

Press COUNTER MEMORY button.

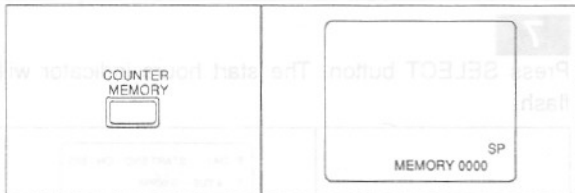

4

Press REC or PLAY button.

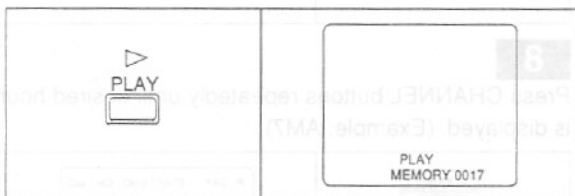

5

Press STOP button when recording or playback is completed.

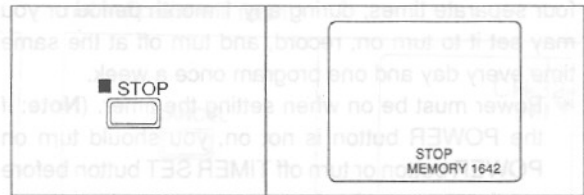

6

Press REW. button.

The tape will stop when the counter reaches to approx. 0000.

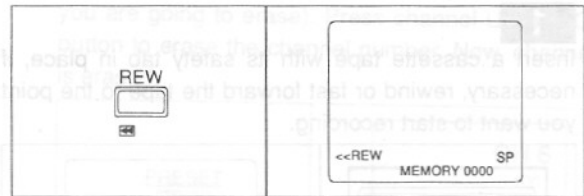

AUTOMATIC TIMER RECORDING

You may set the TVCR to turn on, record and turn off four separate times, during any 1 month period or you may set it to turn on, record, and turn off at the same time every day and one program once a week.

* Power must be on when setting the timer. (Note: If the POWER button is not on, you should turn on POWER button or turn off TIMER SET button before starting timer setting.)

* In the example below, the timer is being set to record channel 32 from 7:30AM to 8:50AM on Tuesday in program number 1. The tape speed is set to EP. The current time is Monday 9:00PM.

1

Insert a cassette tape with its safety tab in place, if necessary, rewind or fast forward the tape to the point you want to start recording.

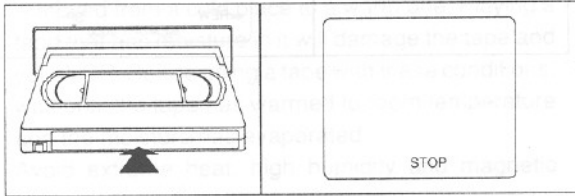

Note:

The following steps, you must use the remote control.

2

Press PROG. button. Program set number 1 will flash.

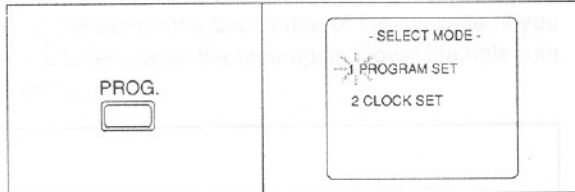

3

Select the "1 PROGRAM SET" with 10 keys and press SELECT button.

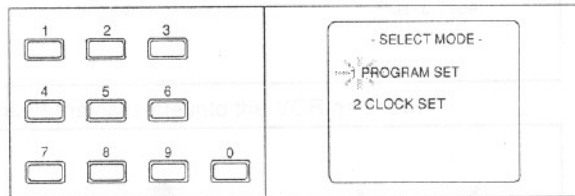

4

Press CHANNEL button, up (or down) until desired program number is displayed. (Example: Program 1)

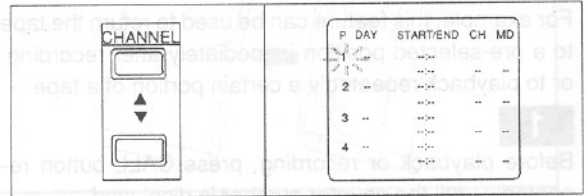

5

Press SELECT button. The day indicator will flash.

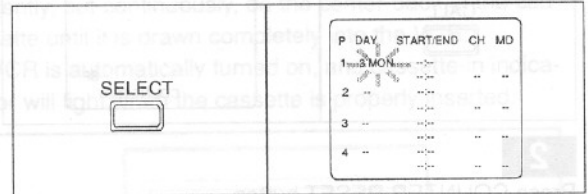

6

Press CHANNEL buttons repeatedly until desired day is displayed. (Example: 4 TUE)

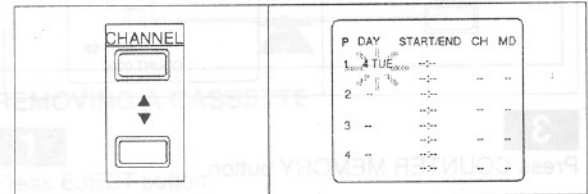

7

Press SELECT button. The start hours indicator will flash.

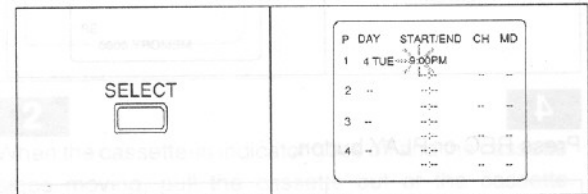

8

Press CHANNEL buttons repeatedly until desired hour is displayed. (Example: AM7)

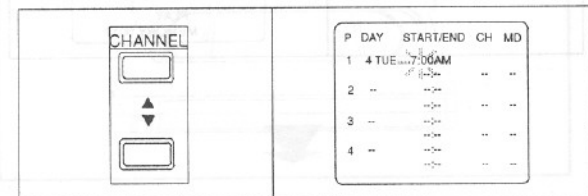

9

Press SELECT button. The start minutes indicator will flash.

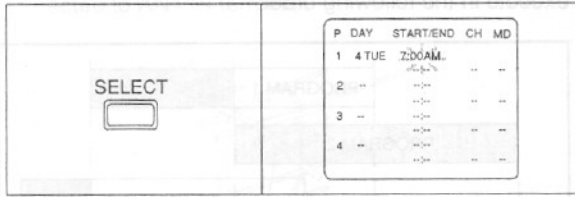
**10**

Press CHANNEL buttons, repeatedly until desired minutes are displayed. (Example: 30)

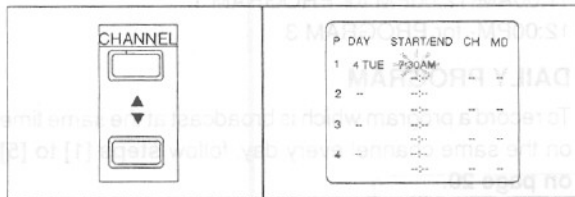
**11**

Press SELECT buttons. The end hours indicator will flash.

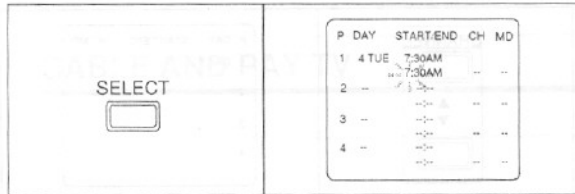
**12**

Press CHANNEL buttons repeatedly until desired hour is displayed. (Example: AM 8)

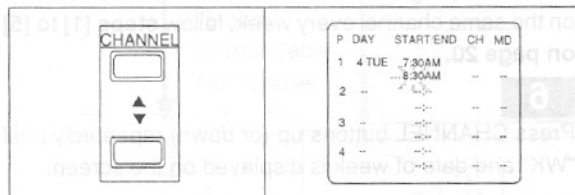
**13**

Press SELECT button. The end minutes indicator will flash.

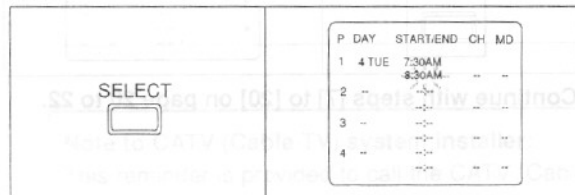
**14**

Press CHANNEL buttons repeatedly until desired minutes are displayed. (Example: 50)

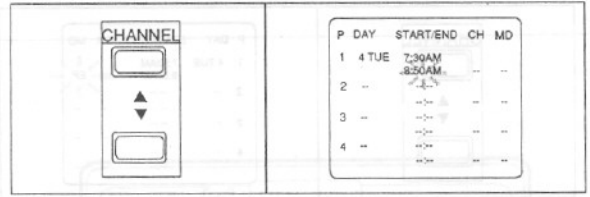
**15**

Press SELECT button. The channel indicator will flash.

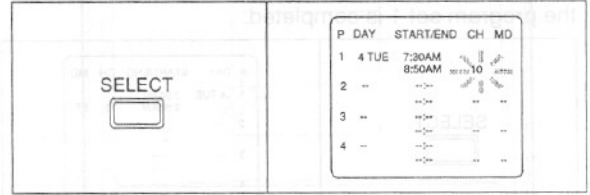
**16**

Press CHANNEL buttons repeatedly until desired channel is displayed. (Example: Channel 32)

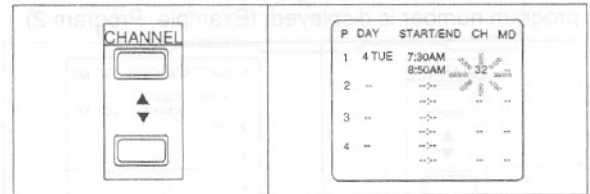
**17**

Press SELECT button. The tape speed indicator will flash.

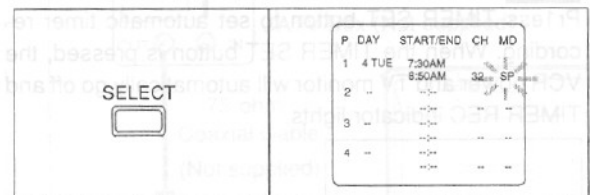

18

Press CHANNEL buttons repeatedly until desired tape speed is displayed. (Example: EP)

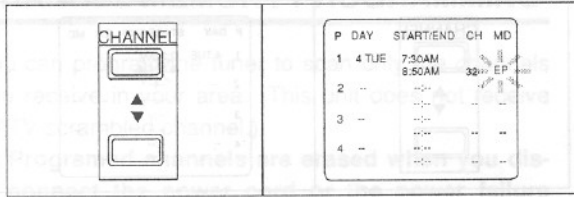
**19**

Press SELECT button, the program #1 will flash. Now the program set 1 is completed.

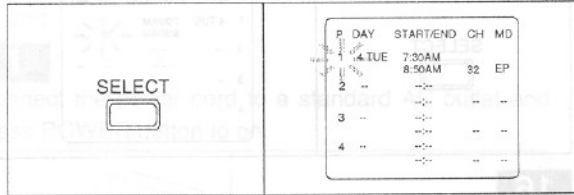
**20**

Press CHANNEL button up (or down) until desired program number is displayed. (Example; Program 2)

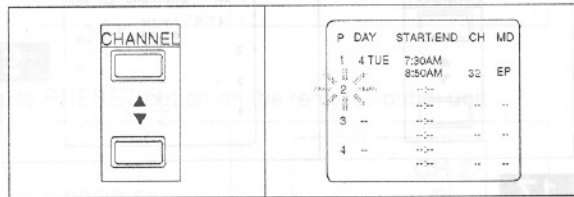

Repeat steps [5] through [20] on page 20 to 22.

21

Press TIMER SET button to set automatic timer recording. When the TIMER SET button is pressed, the VCR power and TV monitor will automatically go off and TIMER REC indicator lights.

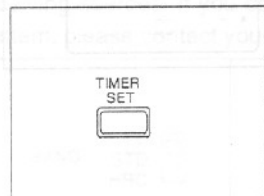
**22**

If the TV monitor doesn't need to be on during Timer Recording, press MONITOR button.



Note: When programs overlap, the earliest time set program has priority.

Example: If you programmed as illustrated, they will execute in the following order.

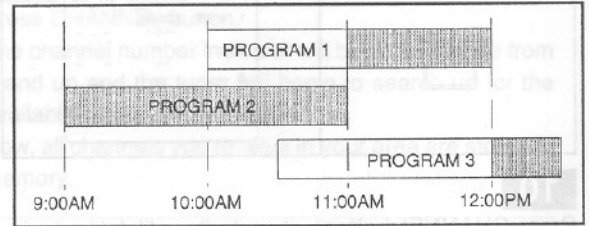

9:00AM-11:00AM for PROGRAM 2

11:00AM-12:00PM for PROGRAM 1

12:00PM- for PROGRAM 3

DAILY PROGRAM

To record a program which is broadcast at the same time on the same channel every day, follow steps [1] to [5] on page 20.

6

Press CHANNEL buttons up (or down) repeatedly until "DAILY" appears on the screen.

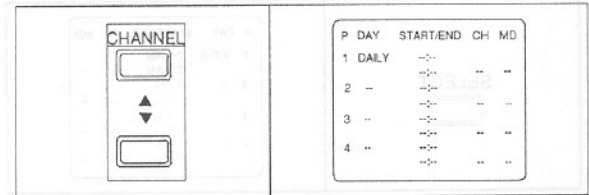

Continue with steps [7] to [20] on page 20 thru 22.

WEEKLY PROGRAM

To record a program which is broadcast at the same time on the same channel every week, follow steps [1] to [5] on page 20.

6

Press CHANNEL buttons up (or down) repeatedly until "WK" and date of week is displayed on the screen.

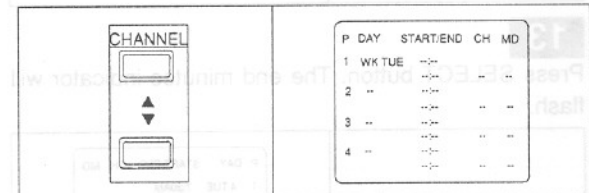

Continue with steps [7] to [20] on page 20 to 22.

TO CANCEL A PRE-PROGRAM

* Timer Recording Mode is off.

Please use buttons on the remote control unit for following steps.

1

Press PROG. button. SELECT MODE appears on the TV screen. Program set number 1 will flash.

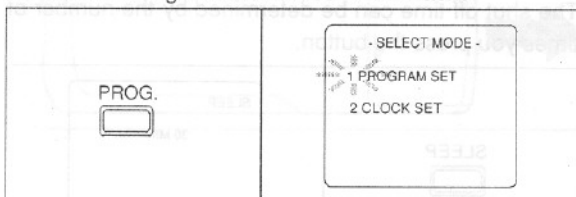

2

Press SELECT button. The program menu will appear.

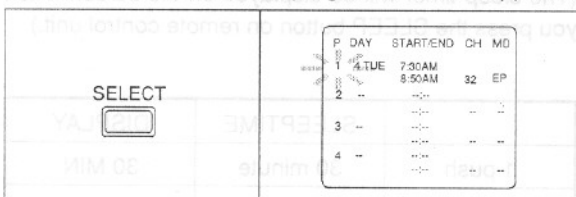

3

Select the desired program number with CHANNEL up (or down) keys. (Example: Program 1)

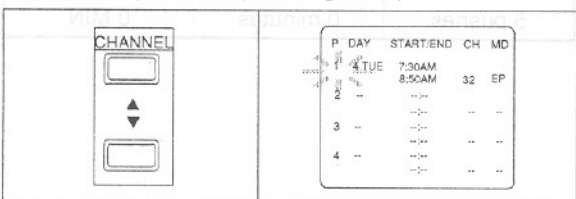

4

Press CANCEL button.

The selected program is erased.

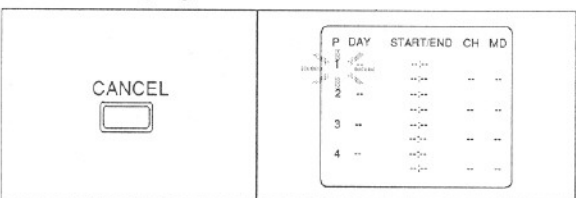

5

Press PROG. button.

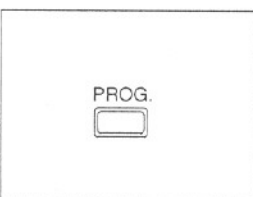

CHECKING THE START/END TIME

After setting the timer recording, to confirm the program number, Start/End time, and channel number.

1

Press POWER button, TIMER-REC indicator still lights.

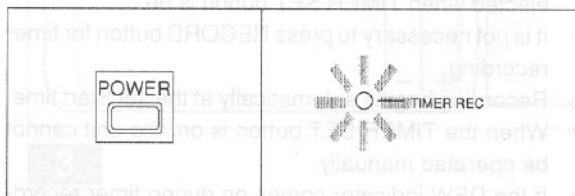

2

Press PROG. button on the remote control unit. The information for all programs appears on the display.

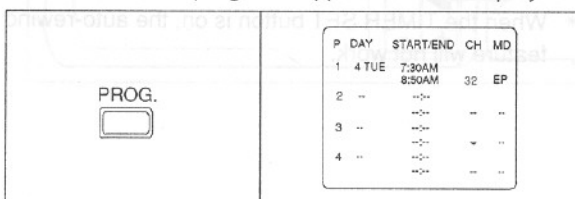

Note:

If the tape runs out before the end time, the TVCR will switch to the stop mode immediately, and tape will be ejected, and the TVCR power will shut off.

TIMER RECORDING HINTS

- * Make sure the channel you want to record is properly tuned in advance.
- * The erase prevention tab on the cassette must be in place (or you must put tape over the hole).
Note: A cassette without erase prevention tab will be ejected when TIMER SET button is on.
- * It is not necessary to press RECORD button for timer recording.
- * Recording begins automatically at the set Start time.
- * When the TIMER SET button is on, the unit cannot be operated manually.
- * If the DEW indicator comes on during timer recording, the unit will stop and will not resume recording, even when the moisture has evaporated.
- * To stop timer recording, turn the TIMER SET button off.
- * When the TIMER SET button is on, the auto-rewind feature will not work.

SETTING THE SLEEP TIMER

The sleep timer function enables you to shut off the power without pressing POWER button after a desired period.

1

Press SLEEP button on the remote control unit. The shut off time can be determined by the number of times you press the button.

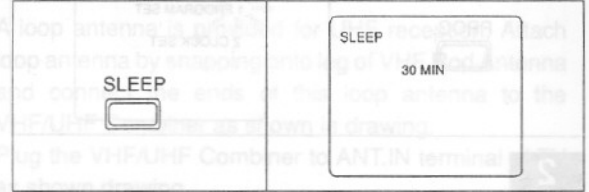

(The sleep timer will be displayed on the screen when you press the SLEEP button on remote control unit.)

	SLEEPTIME	DISPLAY
1 push	30 minute	30 MIN
2 pushes	60 minutes	60 MIN
3 pushes	90 minutes	90 MIN
4 pushes	120 minutes	120 MIN
5 pushes	0 minutes	0 MIN

ONE TOUCH RECORDING

The quick record function enables you to record a program without pressing REC/OTR button once.

According to the table below, simply press REC/OTR button twice as many times as needed, depending upon your required length of recording.

1

Insert a cassette tape (with erasure prevention tab intact).

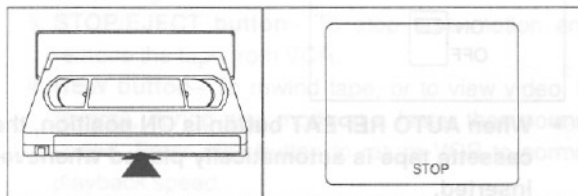

2

Select the program to be recorded.

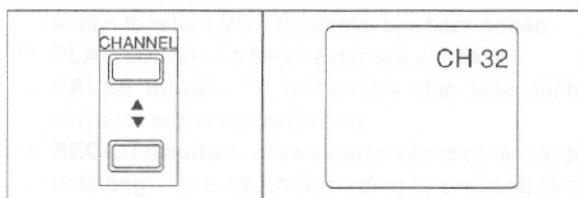

3

Press REC/OTR button

(Example: 4 pushes for 90 minutes)

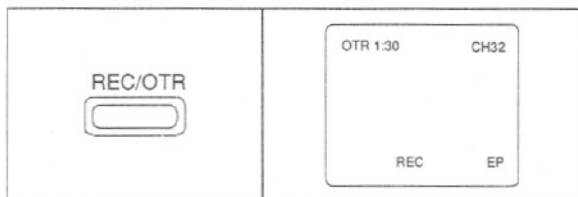

Recording starts if the REC/OTR button is pressed even while watching a TV program.

The recording length can be determined by the number of times you press the button.

Notes:

When the REC/OTR button pressed once recording is continuous.

* When you push REC/OTR button, you will extend recording time by 30 minutes at a time up-to 8 hours (or to the end of the tape).

* Please note that at EP(SLP) (tape speed) mode maximum recording is 8 hours using T-160 (or 6 hours using T-120).

Push(es)	DISPLAY	LENGTH
1	Current Time	Continuous (End of Tape)
2	0:30	30 min
3	1:00	60 min
4	1:30	90 min
5	2:00	120 min
6	2:30	150 min
7	3:00	180 min
8	3:30	210 min
9	4:00	240 min
10	4:30	270 min
11	5:00	300 min
12	5:30	330 min
13	6:00	360 min
14	6:30	390 min
15	7:00	420 min
16	7:30	450 min
17	8:00	480 min
18	Current Time	Continuous (End of Tape)

PLAYBACK

1

When a pre-recorded tape is inserted, the TVCR will turn on automatically, and TAPE-IN indicator lights.

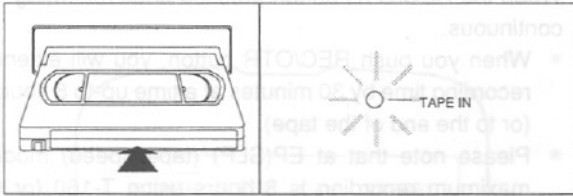

2

Press PLAY button.

If a cassette tape is inserted without its safety tab in place, TVCR start playback automatically.

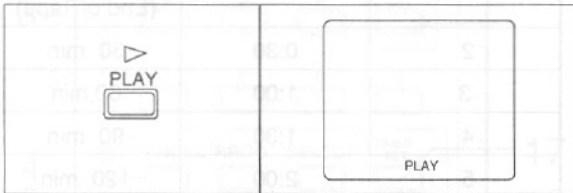

3

Press STOP button when playback is completed.



Note: When playback a pre-recorded tape with COPY-GUARD, On-Screen Display may not display normal position or display nothing.

This is not an indication of the trouble.

AUTO REPEAT PLAYBACK

This unit has an auto repeat playback function that allows you to repeat a tape indefinitely without having to continue to push the PLAY button.

To start auto repeat playback, simply set the AUTO REPEAT switch to on.

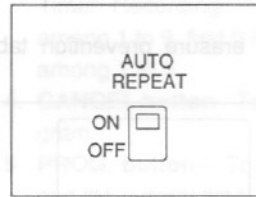

* When AUTO REPEAT button is ON position, the cassette tape is automatically played whenever inserted.

AUTO REWIND-EJECT

When the end of a tape is reached during recording, playback, or fast-forward, the tape will automatically rewind to the beginning (or to the preset counter memory position). The cassette mechanism will disengage after rewinding and the tape will be ejected and the TVCR will shut itself off.

Notes:

- * The tape will not auto-rewind during timer recording and Quick Timer Recording.
- * When tape is rewound to the preset memory position, tape will not be ejected and TVCR will not shut off.

CUE AND REVIEW (VISUAL SEARCH)

You may view the video program at a high speed in either a forward or reverse direction. When in the play mode, press F.FWD button to view the tape at a fast speed in the forward direction. To view the tape at a fast speed in the reverse direction, press REW button. The sound will be muted. This feature is used in finding a particular section of a tape.

Notes:

- * When video searching a pre-recorded tape, it may cause the noise bars (white lines) to move vertically. Also, the picture color fluctuates on and off. This is not an indication of the trouble.
- * You will get best results when playing back tapes that were recorded in the EP mode.
- * To return to normal playback, press PLAY button.
- * The picture will not be as good as normal during CUE and REVIEW.

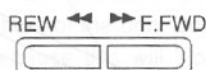

2 STEP SEARCH

This VCR has 2 speeds of visual search with tapes recorded in LP or EP (SLP) mode.

- 1) Push the button for F.FWD or REW during the playback, to view the picture at a faster than normal speed.
- 2) If you want to view the picture at faster than above 1), you can view the picture by holding down the F.FWD or REW button during playback.

STILL FRAME DURING PLAYBACK

If you press PAUSE button during playback with tapes recorded in EP mode, the picture will "freeze" on the screen. You may use this feature to study details of a particular scene. Press PLAY button again to continue playback. If you use the PAUSE button during playback with tapes recorded in the SP or LP mode, it may cause the noise bars to appear more than with tapes recorded in the EP mode. This is not an indication of the trouble.

Note:

The TVCR will automatically switch to the Stop mode, if it is left in the PAUSE/STILL mode for more than five minutes.

NOISE CANCELLING

If you use the PAUSE button to freeze the picture during playback, usually there will be video "noise" lines on the screen. This is normal, however, this unit has a special feature that allows you to reposition or reduce the lines. Each time you press the PAUSE button the lines will change position on the screen.

This enables you to see the picture in its entirety without distracting noise lines.

TRACKING CONTROL KNOB

When the noise appears during playback, adjust the TRACKING control to achieve the best picture.

Note:

For tapes recorded on your TVCR, the center setting is usually best. Tapes recorded on other VCRs may require adjustment. If you encounter video "noise" during playback adjust the knob to the right or left to achieve the best picture.

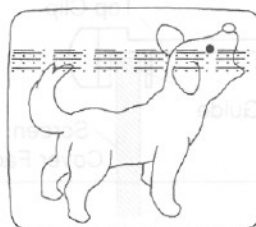

STEPS

Clip towards #1 direction.

Top Clip(s) towards #2 direction.

over.

Do not remove the bottom Clips.

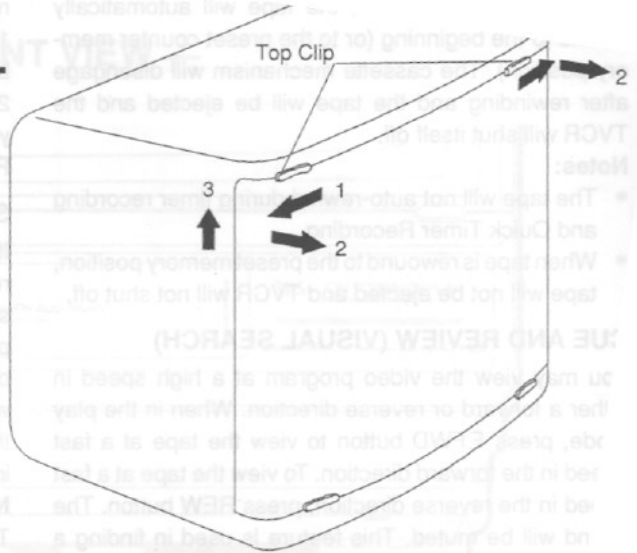

INSTALLATION STEPS

Do not miss use Clips between the left one and the right one.

Place the screen cover on the bottom Clips.

2

Place the top Clips on the top of screen cover and the Clip and screen cover together

3

Place the Clips into the hole.

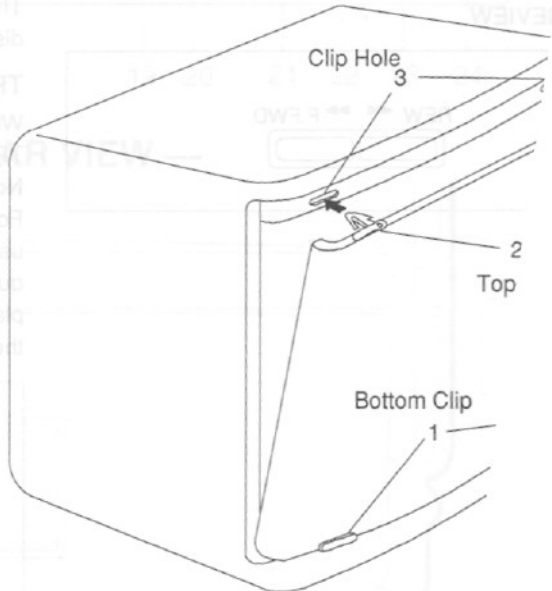
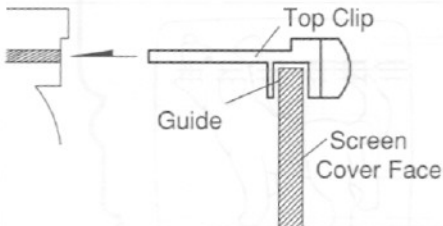
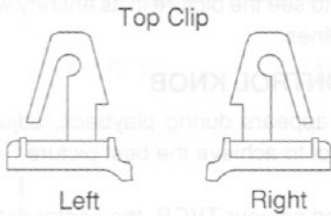

TROUBLESHOOTING GUIDE

If you have followed the instructions contained in this manual and have difficulty in operating your unit, locate the SYMPTOM in the left column below. Check the corresponding POSSIBLE CAUSE and CORRECTIVE ACTION columns to locate and remedy the problem.

SYMPTOM	POSSIBLE CAUSE	CORRECTIVE ACTION
No power.	<ul style="list-style-type: none"> * Power cord is not connected. * Power is turned off. * TIMER SET is on. 	<ul style="list-style-type: none"> * Connect power cord to AC outlet. * Push Power button on. * Push TIMER SET. button off.
No picture and sound.	<ul style="list-style-type: none"> * TV is not plugged into an active AC outlet. * Antenna is not connected. * No channel in memory. 	<ul style="list-style-type: none"> * Plug power cord into an active AC outlet. * Check antenna connection. * Program tuner's memory
Sound OK; poor picture.	<ul style="list-style-type: none"> * Direction or condition of antenna is not good. * Picture control is not good. * Interconnecting cable is connected to another source. 	<ul style="list-style-type: none"> * Adjust direction or replace antenna. * Adjust picture controls. * Connect incoming antenna directly to the television.
Picture OK; poor or no sound.	<ul style="list-style-type: none"> * Volume control on remote control unit or set is in minimum position. * MUTE button on the remote control unit is in the ON position. 	<ul style="list-style-type: none"> * Adjust volume control on remote control unit or set. * Release MUTE button
Timer recording is not possible.	<ul style="list-style-type: none"> * The program timer is set incorrectly. * The TIMER SET is turned off. 	<ul style="list-style-type: none"> * Set the program timer correctly. * Push TIMER SET button on.
Record mode cannot be engaged.	<ul style="list-style-type: none"> * The erasure prevention tab on cassette is missing. 	<ul style="list-style-type: none"> * Place vinyl tape over missing erasure prevention tab.
Picture is poor on playback.	<ul style="list-style-type: none"> * The TRACKING control is not set to best position. * The TV fine tuning is not set correctly. 	<ul style="list-style-type: none"> * Adjust TRACKING control for better picture. * Fine tune your TV.
Noise in picture on playback.	<ul style="list-style-type: none"> * Video head is dirty. 	<ul style="list-style-type: none"> * Head cleaning is necessary, consult the nearest dealer.
Operation buttons do not work when power is on and cassette is inserted.	<ul style="list-style-type: none"> * DEW indicator "d" is on. 	<ul style="list-style-type: none"> * Wait until indicator goes off, then proceed with operation.
No operation by infrared Remote Control.	<ul style="list-style-type: none"> * No power to TV or VCR. * Weak battery. 	<ul style="list-style-type: none"> * Make sure the AC cord is connected to an AC outlet. * Check the batteries of infrared Remote Control.

MAINTENANCE

CABINET CLEANING

- * Wipe the front panel and other exterior surfaces of the unit with a soft cloth immersed in lukewarm water and wrung dry.
- * Never use a solvent or alcohol. Do not spray insecticide liquid near the unit. Such chemicals may cause damage and discoloration to the exposed surfaces.

VCR HEAD CLEANING

- * Picture playback may become blurred or interrupted while the TV program received is clear. This does not mean that

the recorded program has been erased.

Dirt accumulated on the head after long periods of use causes this problem. Head cleaning requires highly technical skill. Clean heads only when symptom occurs. Bring the unit to your nearest Service Center for a complete cleaning of the heads and cassette compartment.

SERVICING

- * Should your unit become inoperative, do not try to correct the problem by yourself. There are no user-serviceable parts inside. Switch power off, unplug the power cord, and take the unit to your nearest Service Center for servicing.

SPECIFICATIONS

GENERAL SPECIFICATIONS

CRT: 13 inch in-line gun,
90 deflection tube

Television system: NTSC-M

Recording system: Rotary two-head
helical scan system

Tape width: 1/2 inch

Tape speed
SP :33.40mm/sec.
LP :16.67mm/sec.
EP (SLP) :11.12mm/sec.

Tuner channel
TV VHF Low :#2~#6
TV VHF High :#7~#13
TV UHF :#14~#69
CATV

ELECTRICAL SPECIFICATIONS

Video input level: 0.5~2.0V_{p-p}

Audio input level: -15dBs

Video S/N ratio: More than 46dB

Audio S/N ratio: More than 43dB

OTHER SPECIFICATIONS

Power requirement: AC 120V/60Hz

Power consumption: 85W

Dimensions: 362(W) x 372(D) x 399(H) mm

Weight: 13.5 kg
29.7 lbs

* Design and specifications are subject to change without notice.

SELECTED CHANNEL INDICATION	CHANNEL BAND DESIGNATIONS	CATV CHANNEL RECEIVED FROM CABLE
2~13	BROADCAST VHF	2~13
14~36	CATV MID/SUPER BANDS	A~W
37~64	CATV HYPER BAND	W+1~W+28
95~99	CATV LOW BAND	A-5~A-1
65~94	ULTRA BAND	W+29~W+58
1	SPECIAL CATV CHANNEL	5A(between 4 and 5)

Terminals:

Antenna input VHF/UHF 75 ohms unbalanced

Video input RCA connector

Audio input RCA connector

The serial number of this product may be found on the back of the unit. No others have the same serial number as yours. You should record the number and other vital information here and retain this book as a permanent record of your purchase to aid identification in case of theft.

Date of Purchase	
Dealer Purchased from	
Dealer Address	
Dealer Phone No.	
Model No.	13TVCR MKIVS
Serial No.	

FUNAI CORPORATION d/b/a SYMPHONIC LIMITED WARRANTY

FUNAI CORP./SYMPHONIC will repair this product, free of charge in the USA in the event of defect in materials or workmanship as follows:

DURATION:

PARTS: FUNAI CORP./SYMPHONIC will provide parts to replace defective parts without charge for one (1) year from the date of original retail purchase. Two (2) years for Picture Tube. Certain parts are excluded from this warranty.

LABOR: FUNAI CORP./SYMPHONIC will provide the labor without charge for a period of ninety (90) days from the date of original retail purchase.

LIMITS AND EXCLUSIONS:

This warranty is extended only to the original retail purchase. A purchase receipt or other proof of original retail purchase will be required together with the product to obtain service under this warranty.

This warranty is void and of no effect if any serial numbers on FUNAI/SYMPHONIC product are altered, replaced, defaced or missing. This FUNAI/SYMPHONIC warranty does not apply to any FUNAI/SYMPHONIC product not purchased and used in the United States.

This warranty only covers failures due to defects in material or workmanship which occurs during normal use. It does not cover damage which occurs in shipment, or failures which are caused by repairs, alterations or product not supplied by FUNAI CORP./SYMPHONIC, or damage which results from accident, misuse, abuse, mishandling, misapplication, alteration, faulty installation, improper maintenance, commercial use such as hotel, rental or office use of this product or damage which results from fire, flood, lightning or other acts of God.

THIS WARRANTY DOES NOT COVER PACKING MATERIALS, ANY ACCESSORIES, ANY COSMETIC PARTS, COMPLETE ASSEMBLY PARTS.

FUNAI CORP./SYMPHONIC AND ITS REPRESENTATIVES OR AGENTS SHALL IN NO EVENT BE LIABLE FOR ANY GENERAL, INDIRECT OR CONSEQUENTIAL DAMAGES ARISING OUT OF OR OCCASIONED BY THE USE OF OR THE INABILITY TO USE THIS PRODUCT. THIS WARRANTY IS MADE IN LIEU OF ALL OTHER WARRANTIES, EXPRESS OR IMPLIED, AND OF ALL OTHER LIABILITIES ON THE PART OF FUNAI/SYMPHONIC. ALL OTHER WARRANTIES INCLUDING THE WARRANTY OF MERCHANTABILITY, AND FITNESS FOR A PARTICULAR PURPOSE, ARE HEREBY DISCLAIMED BY FUNAI/SYMPHONIC AND ITS REPRESENTATIVES IN THE UNITED STATES.

ALL WARRANTY SERVICE MUST BE PERFORMED BY A FUNAI/SYMPHONIC AUTHORIZED SERVICE CENTER. THIS WARRANTY IS VALID WHEN THE UNIT IS CARRIED-IN TO FUNAI/SYMPHONIC AUTHORIZED SERVICE FACILITY.

WHEN YOU ARE RETURNING THE PRODUCT FOR SERVICE TO FACTORY SERVICE CENTER, PLEASE CONTACT THE FUNAI/SYMPHONIC SERVICE DEPARTMENT TO RECEIVE M.R.A. (MERCHANDISE RETURN AUTHORIZATION) NUMBER. ANY POSTAGE, INSURANCE AND SHIPPING COST, INCURRED IN PRESENTING OR SENDING YOUR FUNAI/SYMPHONIC PRODUCT FOR SERVICE ARE SHIPPER'S RESPONSIBILITY.

CAREFULLY PACK WITH PROPER PACKING MATERIALS, PREFERABLY IN THE ORIGINAL CARTON.

ATTACH DETAILING THE COMPLAINT, TO THE OUTSIDE OR INSIDE OF THE CARTON.

THE PRODUCT MUST BE ACCOMPANIED BY A PROOF OF ORIGINAL RETAIL PURCHASE RECEIPT OR A COPY. THERE OF NO PROOF OF PURCHASE IS ATTACHED, THE WARRANTY CANNOT BE HONORED AND REPAIRS COSTS WILL BE CHARGED.

IMPORTANT:

THIS LIMITED WARRANTY GIVES YOU THE LEGAL RIGHTS, AND YOU MAY HAVE OTHER RIGHTS THAT VARY FROM STATE TO STATE. IF, AT ANY TIME DURING THE WARRANTY PERIOD, YOU ARE UNABLE TO OBTAIN SATISFACTION WITH THE REPAIR ON THIS PRODUCT, PLEASE CONTACT FUNAI CORP./SYMPHONIC.

ATTENTION:

FUNAI CORP./SYMPHONIC RESERVES THE RIGHT TO MODIFY ANY DESIGN OF THIS PRODUCT WITHOUT PRIOR NOTICE.

For information of your nearest FUNAI/SYMPHONIC Authorized Service Center or general service procedure, please call or write to the following:

FUNAI CORPORATION DBA SYMPHONIC
Corporate Headquarters & Factory Service Center
Address :100 North Street Teterboro, NJ 07608
Tel :201-288-2666
(Eastern Time 9:00 AM - 4:30 PM)

IMPORTANT: When you return for service to Factory Service Center, please call for Repair Return Authorization prior to shipping.